



Captor
Therapeutics[®]

*Pioneering targeted protein
degraders for human health*

Corporate Presentation

October 2024

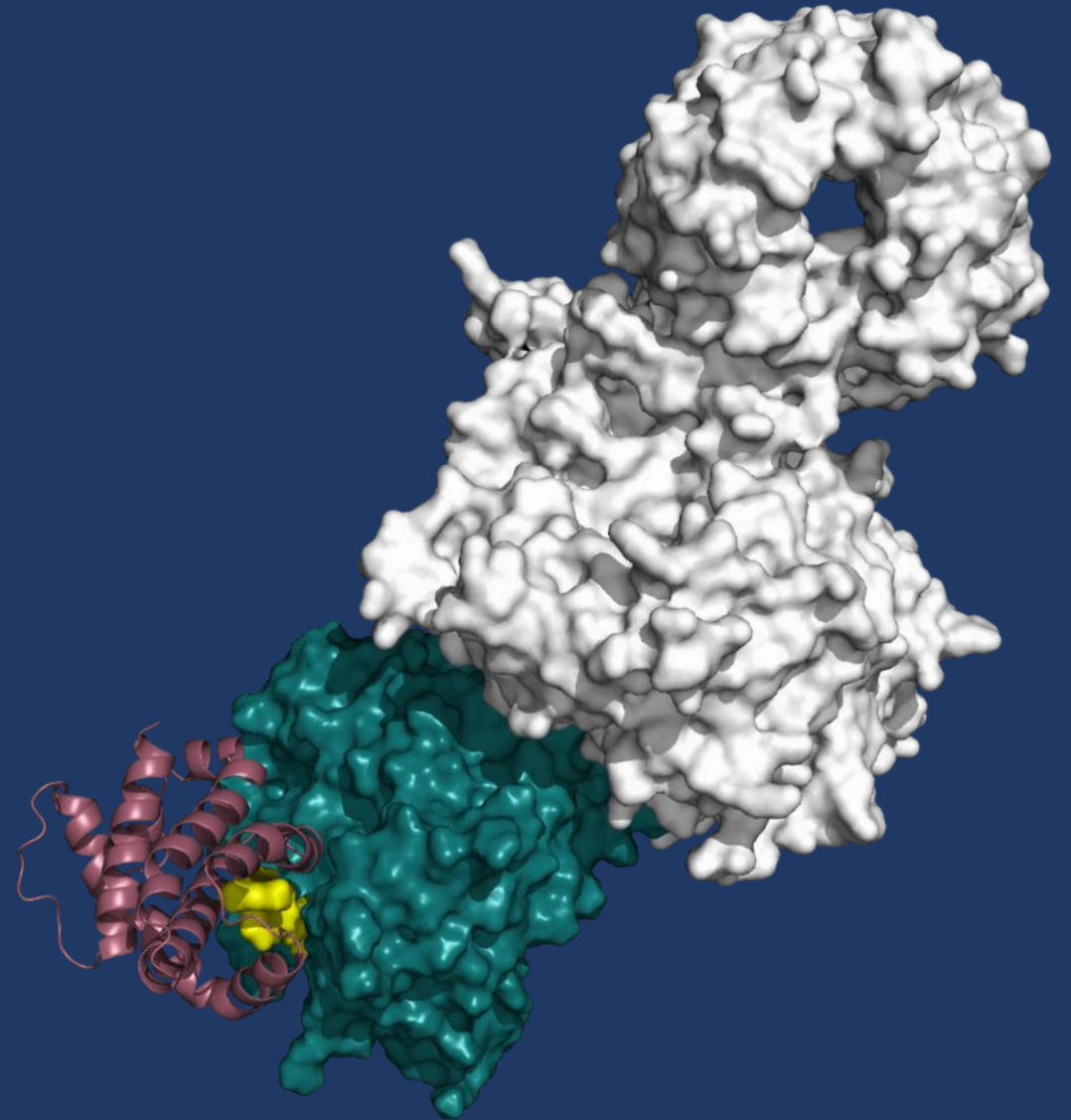

Legal notice

This document and the information contained herein (unless otherwise indicated) have been prepared by Captor Therapeutics S.A. (the “Issuer”) solely for informational purposes. For this notice, the presentation that follows shall mean and include the slides that follow, the oral presentation of the slides by the Issuer or any person on behalf of the Issuer, any question-and-answer session that follows the oral presentation, hard copies of this document, and any materials distributed at, or in connection with the presentation (collectively, the “Presentation”). By attending the meeting at which the Presentation is made, or by reading the Presentation, you will be deemed to have (i) agreed to all of the following restrictions and made the following undertakings and (ii) acknowledged that you understand the legal and regulatory sanctions attached to the misuse, disclosure or improper circulation of the Presentation.

The information contained in this Presentation may not be reproduced or redistributed in any way, in whole or in part, to any other person without the prior written consent of the Issuer. This Presentation does not purport to contain all the information that may be required by the recipient to assess the Issuer or its securities. The Issuer prepared this Presentation based on the information which it has and from sources believed to be reliable. To the extent available, the industry, market, and competitive position data contained in this Presentation come from official or third-party sources. There is no guarantee of the accuracy or completeness of such data.

This Presentation contains neither a complete nor a comprehensive financial or commercial analysis of the Issuer, nor does it present its position or prospects in a complete or comprehensive manner. The Issuer has prepared the Presentation with due care, however certain inconsistencies or omissions might have appeared in it. Therefore it is recommended that any person who intends to undertake any investment decision regarding any security issued by the Issuer shall only rely on information released as an official communication (i.e., current/periodic reports) in accordance with the legal and regulatory provisions.

This Presentation may contain certain forward-looking statements, forecasts, estimates, projections, and opinions (“Forward-looking Statements”). By their nature, Forward-looking Statements involve known and unknown risks, uncertainties, assumptions, and other factors because they relate to events and depend on circumstances that will occur in the future whether or not outside the control of the Issuer. No representation is made or will be made that any Forward-looking Statements will be achieved or will prove to be correct. Actual future results and operations could vary materially from the Forward-looking Statements. Similarly, no representation is given that the assumptions disclosed in this Presentation upon which Forward-looking Statements may be based are reasonable. The recipient acknowledges that circumstances may change and the contents of this Presentation may become outdated as a result. The assumptions included herein do not constitute profit forecasts or profit estimates.

No warranties or representations can be made as to the comprehensiveness or reliability of the information contained in this Presentation. Neither the Issuer nor its directors, managers, advisers or representatives of such persons shall bear any liability that might arise in connection with any use of this Presentation. Furthermore, no information contained herein constitutes an obligation or representation of the Issuer, its managers or directors, its shareholders, subsidiary undertakings, advisers or representatives of such persons. Data contained in this Presentation is valid as of the day of its preparation. Consequently, this Presentation will not be subject to changes, updates or modifications to account for events which might occur after this day.

This Presentation does not constitute or form part of, and should not be construed as, an offer to sell or issue, or the solicitation of an offer to purchase, subscribe to, or acquire the Issuer or the Issuer’s securities, or an inducement to enter into investment activity in any jurisdiction in which such offer, solicitation, inducement or sale would be unlawful before registration, exemption from registration or qualification under the securities laws of such jurisdiction. No part of this Presentation, nor the fact of its distribution, should form the basis of, or be relied on in connection with, any contract or commitment or investment decision whatsoever. This presentation is not for publication, release, or distribution in any jurisdiction where to do so would constitute a violation of the relevant laws of such jurisdiction nor should it be taken or transmitted into such jurisdiction.

An experienced leadership team



Tom Shepherd, Ph.D.
Chief Executive Officer

- 30 years in Biotech leadership positions
- Led 12 licensing transactions resulting in > \$3 B in sales
- 6 private investment rounds and 3 IPOs.



Michal Walczak, Ph.D.
Co-founder
Chief Scientific Officer

- Ph.D. ETH Zurich,
- Post-doc FMI Basel (Novartis Research Foundation) on TPD
- 10 years in drug discovery and TPD



Anna Pawluk, Ph.D.
VP Operation

- Ph.D. University of Wroclaw
- MBA WSH in Wroclaw
- 15 years of R&D experience



Sylvain Cottens, Ph.D.
Co-founder
SVP Chemistry

- Ph.D. EPFL Lausanne,
- Post-doc Caltech, (USA)
- Scientific expert & leader with 25+ years at Novartis
- Co-inventor of Afinitor and co-developer of Gilenya (both blockbuster drugs)



Andrew Saunders DPM, FFPM
Chief Medical Officer

- MB BCh BAO BA, Medicine, Trinity College, Dublin
- FFPM, Royal College of Physicians, London
- 25 years in oncology clinical development, including global responsibility for Rituximab

EDUCATION



ETH



Wyższa Szkoła Handlowa we Wrocławiu

EPFL



PREVIOUS EXPERIENCE

BAUSCH+Health
kymab

FMI
Friedrich Miescher Institute
for Biomedical Research

NOVARTIS

Lilly

Roche

Targeted Protein Degradation expected to unlock \$974* bn by 2030

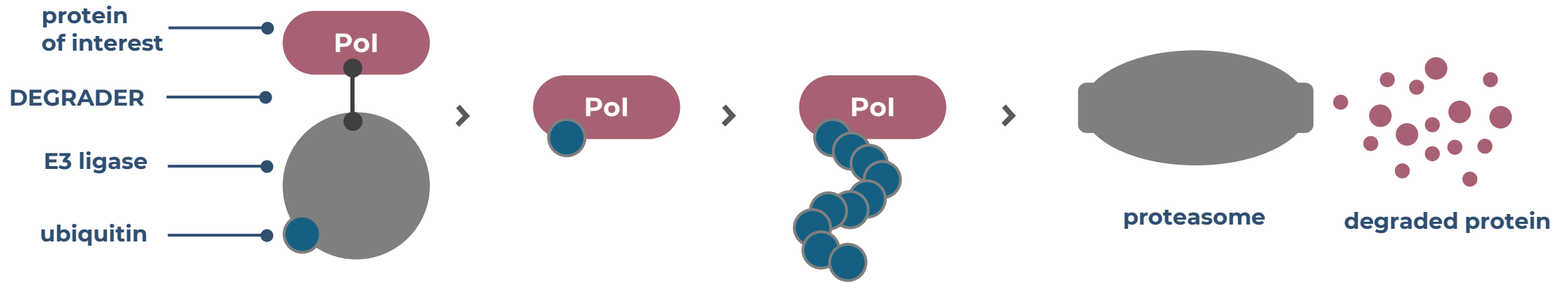

	Degraders	Inhibitors	mAbs	siRNA
Removing multiple pathological functions	✓✓✓	✗	✗	✓✓✓
Oral bioavailability	✓✓✓	✓✓✓	✗	✗
Uncoupling PK from PD = prolonged efficacy	✓✓✓	✗	✗	✓✓✓
Overcoming mutational resistance	✓✓✓	✓	✓✓	✓✓✓
Targeting scaffolding function	✓✓✓	✗	✓✓	✓✓✓
Brain-penetration	✓✓	✓✓✓	✗	✗
Accessing undrugged proteins	✓✓✓	✓	✗	✓✓✓

*Biopharmaceuticals Market by Type and Application: Global Opportunity Analysis and Industry Forecast, 2022-2030
 4 Business Use Only | All rights reserved

Optigrade™ discovery platform – importance of structure

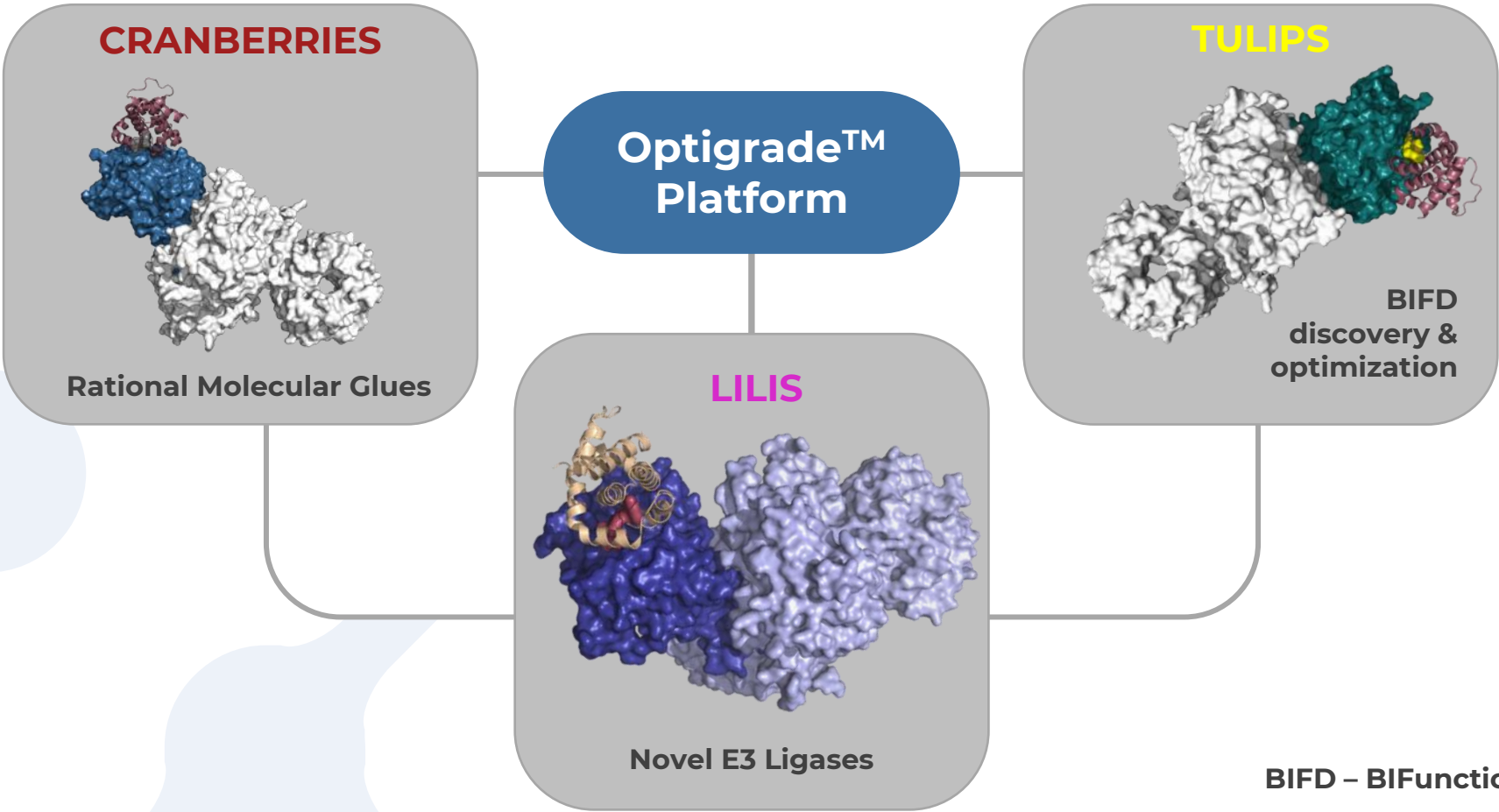

Optigrade™ – addressing Molecular Glues, Bifunctional Degraders and novel E3 Ubiquitin Ligases

CT-01: First-in-Class GSPT1 Targeted Degradator for Hepatocellular Carcinoma (HCC)

CT-01: first-in-class molecular glue degrader of GSPT1 & NEK7

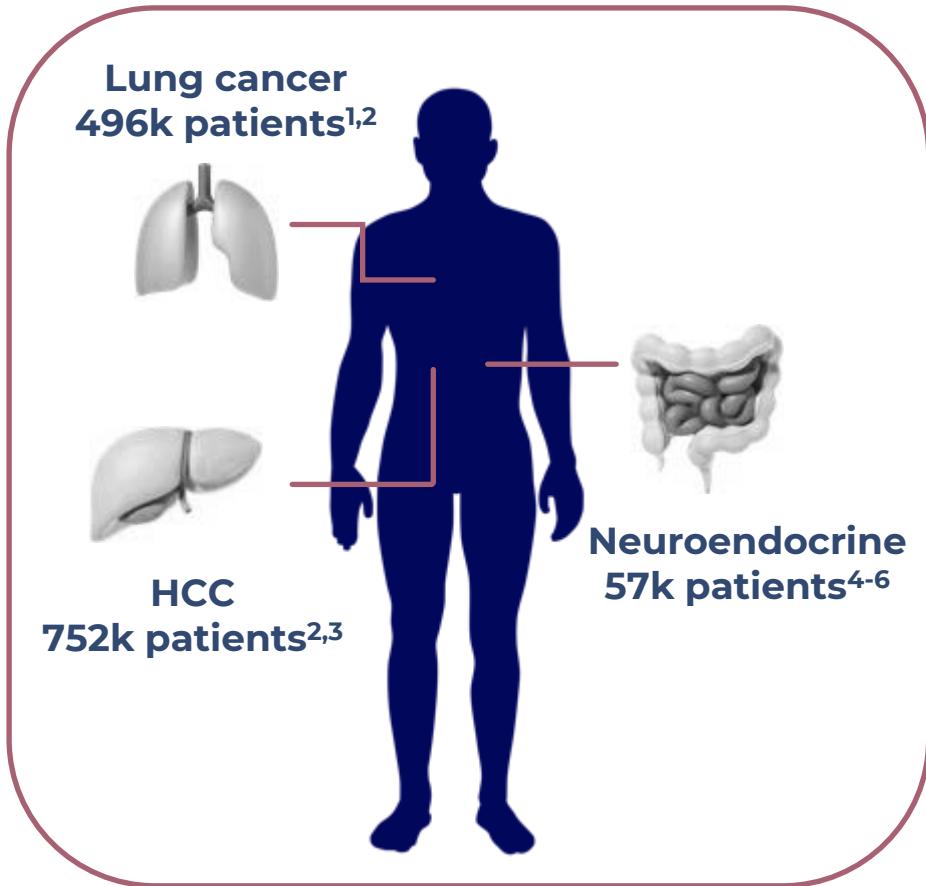

GSPT1 degradation leads to an Integrated Stress Response (ISR) and induction of apoptosis in HCC cells

NEK7 degradation leads to reduction of IL-1 β production – a well-established pro-carcinogenic factor. Reduction of IL-1 β levels in the tumor microenvironment enables activation of the immune response

CT-01 is a pro-drug activated by an enzyme present at high levels in the liver, lungs and certain gastrointestinal tumors

A unique degradation profile combined with target tissue pro-drug activation for liver, lung, breast and neuroendocrine cancer

Biology of GSPT1 supports its targeted degradation in cancer treatment

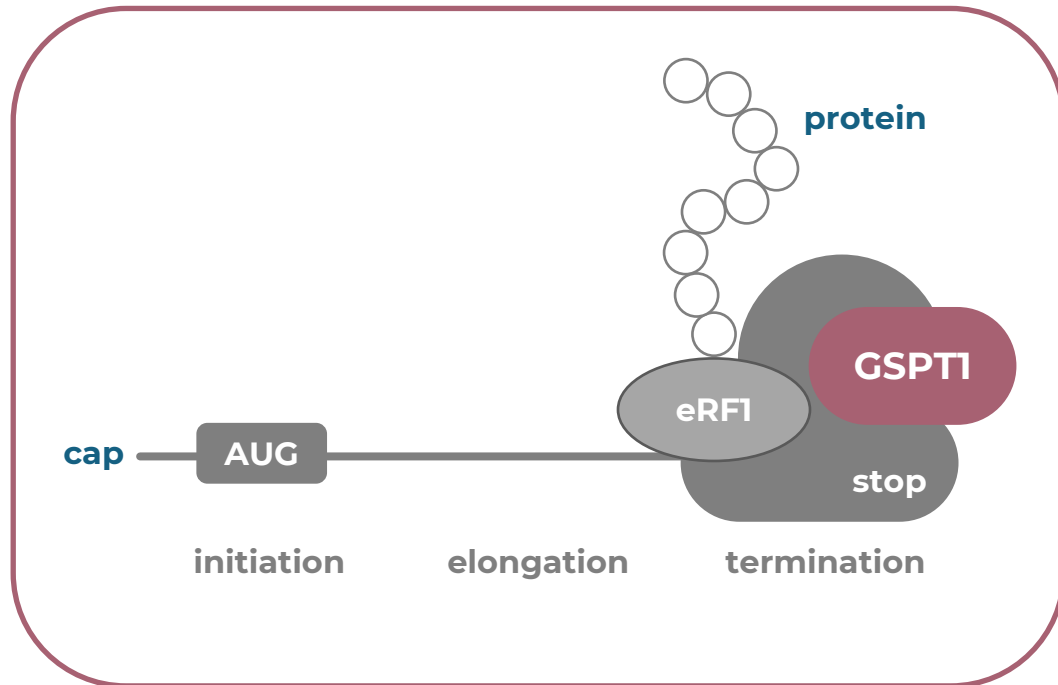

1. Hellen C. U. T., *Cold Spring Harb Perspect Biol*, 2018
2. Salas-Marco, J. & Bedwell, D. M., *Mol Cell Biol*, 2004
3. Kurosaki, T. & Maquat, L. E., *J Cell Sci*, 2016

Target Biology and Therapeutic Rationale

G1 to S phase transition 1 protein (GSPT1, eRF3a)

is a translation termination factor that regulates mRNA translation¹

GSPT1 and eRF1 form a translation termination complex that facilitates the nonsense mediated mRNA Decay^{2,3}

Clinical opportunity

Targeting protein translation GSPT1 degradation offers treatment options of:

1. Hepatocellular Carcinoma (HCC)
2. Lung cancer
3. Breast cancer
4. Gliomas
5. Rare cancers, e.g.: hepatoblastoma, angio- and liposarcomas

GSPTI degrader

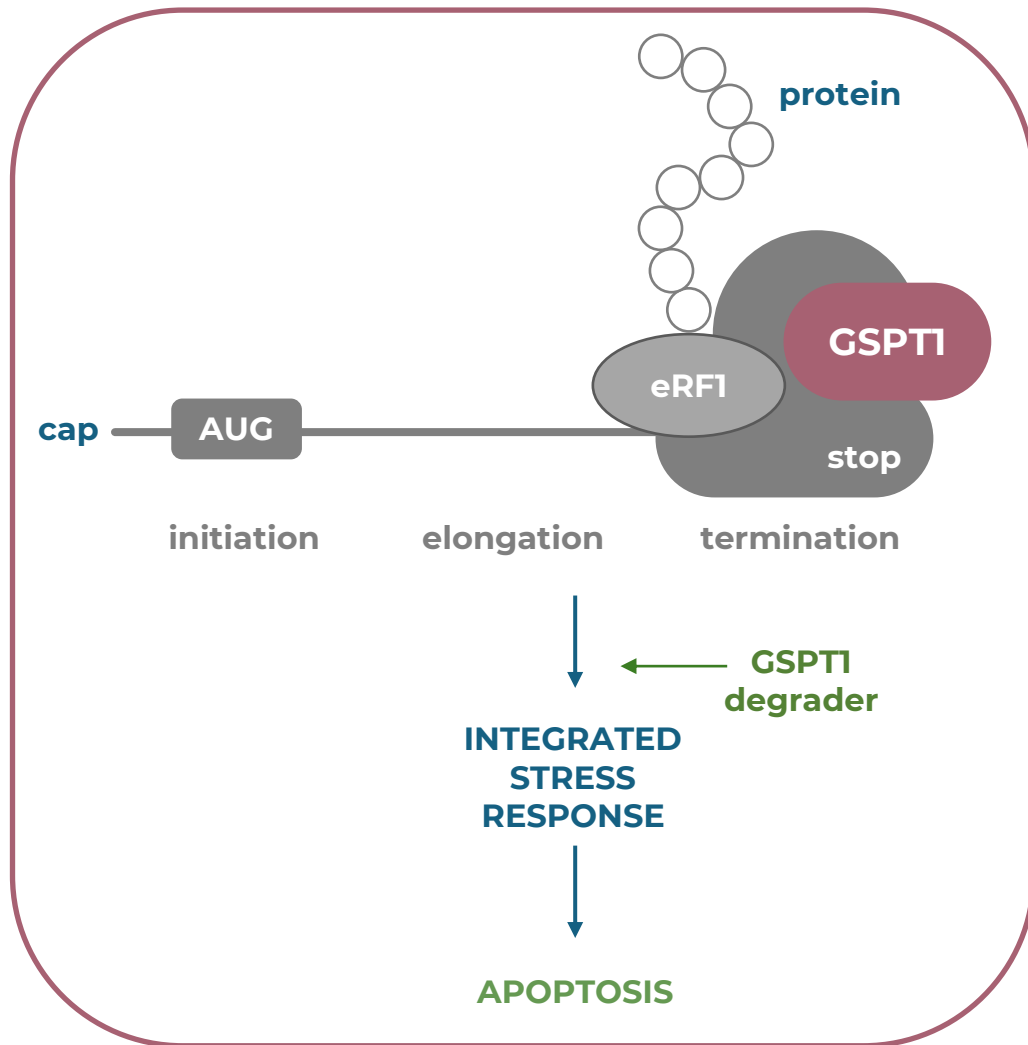

GSPTI degradation leads to apoptosis via induction Integrated Stress Response (ISR)

An excellent opportunity for targeting of cancer cells that require translational adaptations and efficient protein synthesis

CT-01 degrader is a pro-drug converted by an enzyme elevated in the inflammed liver, lungs and blood-brain barrier.

The active molecule is released in HCC and features:

- 1) poor cell membrane penetration and
- 2) fast clearance, both of which significantly expand the therapeutic window.

CT-01 degrades also NEK7, whose pro-carcinogenic role is manifested in stabilization of MDSCs and TAMs in Tumor Micro-Environment (TME)

HCC: current standard of care and opportunity

Line of therapy	Therapy	Survival Benefit vs Sorafenib [months]	FDA Approval
1	Tecentriq + Avastin	+5.8 ¹	uHCC / mHCC
1	Imfinzi + Imjudo	+2.7 ²	uHCC
1/2	Nexavar	0.0 ³	uHCC
2	Optivo	+1.7 ⁴	uHCC (Post sorafenib)
2	Cabometyx	+2.2 ⁵	uHCC (Post sorafenib)

Market Research Provider	Base (Year / \$B)	Future (Year / \$B)	CAGR (%)
Vision Research Reports ⁶	2024: \$3.2	2033: \$11.6	15%
SNS Insider ⁷	2022: \$2.9	2030: \$12.9	20%
Skyquest ⁸	2022: \$2.7	2030: \$11.4	20%
Research and Markets ⁹	2022: \$2.4	2030: \$7.8	15%
Polaris ¹⁰	2021: \$2.2	2030: \$10.4	20%

Global market reports forecast **15-20% CAGR**

uHCC – unresectable HCC
mHCC – metastatic HCC

Induction of ISR-dependent cell death in Hep3B tumor cells

Degradation of GSPT1 in the function of time (WB densitometry)

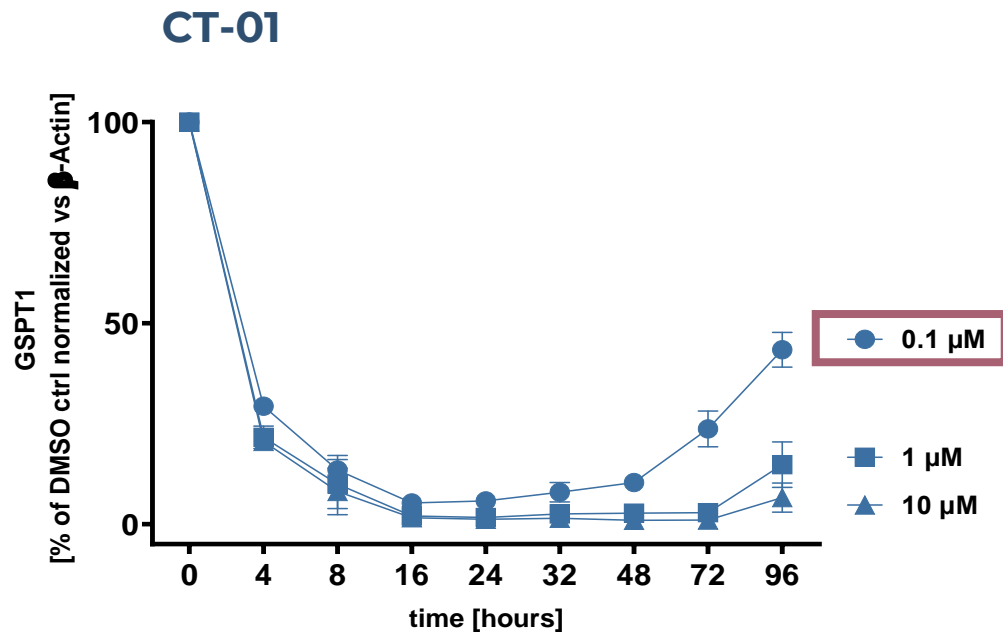

ISR markers during CT-01 treatment

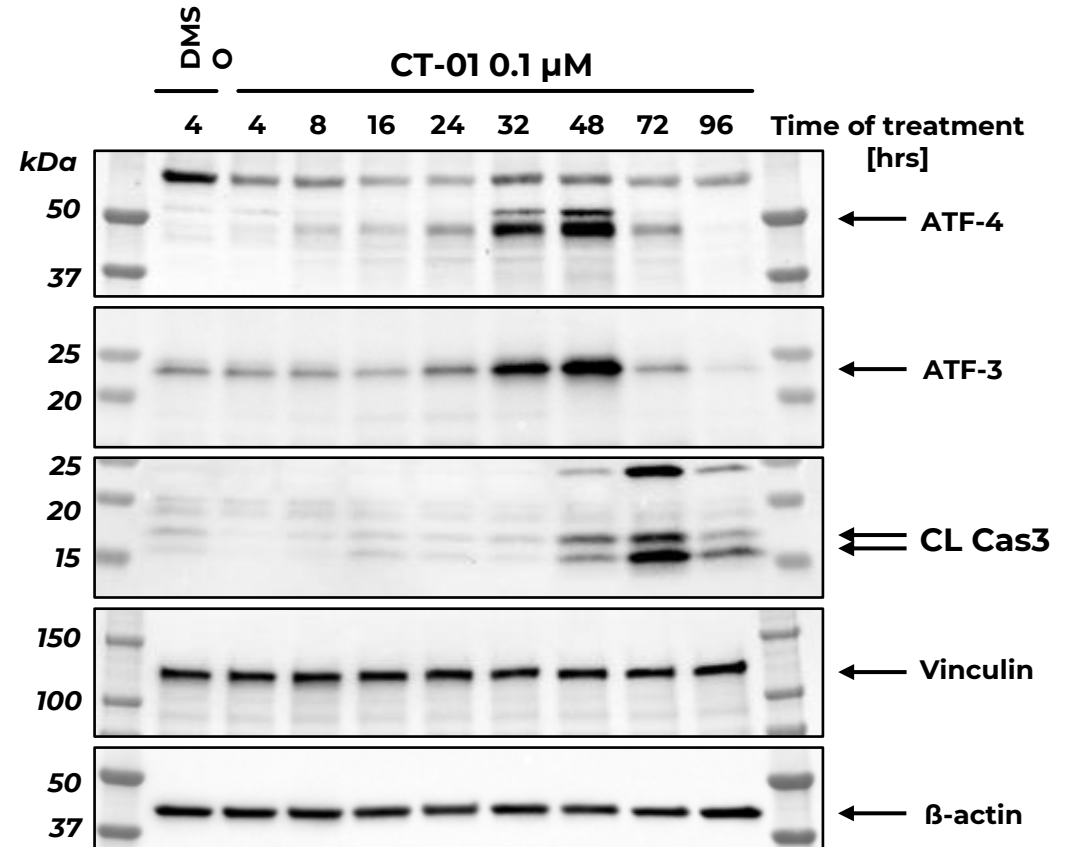

Hep3B cells, 96h treatment with 0.1, 1 and 10 μM compound

Lack of cytotoxicity to primary human hepatocytes provides extra safety level

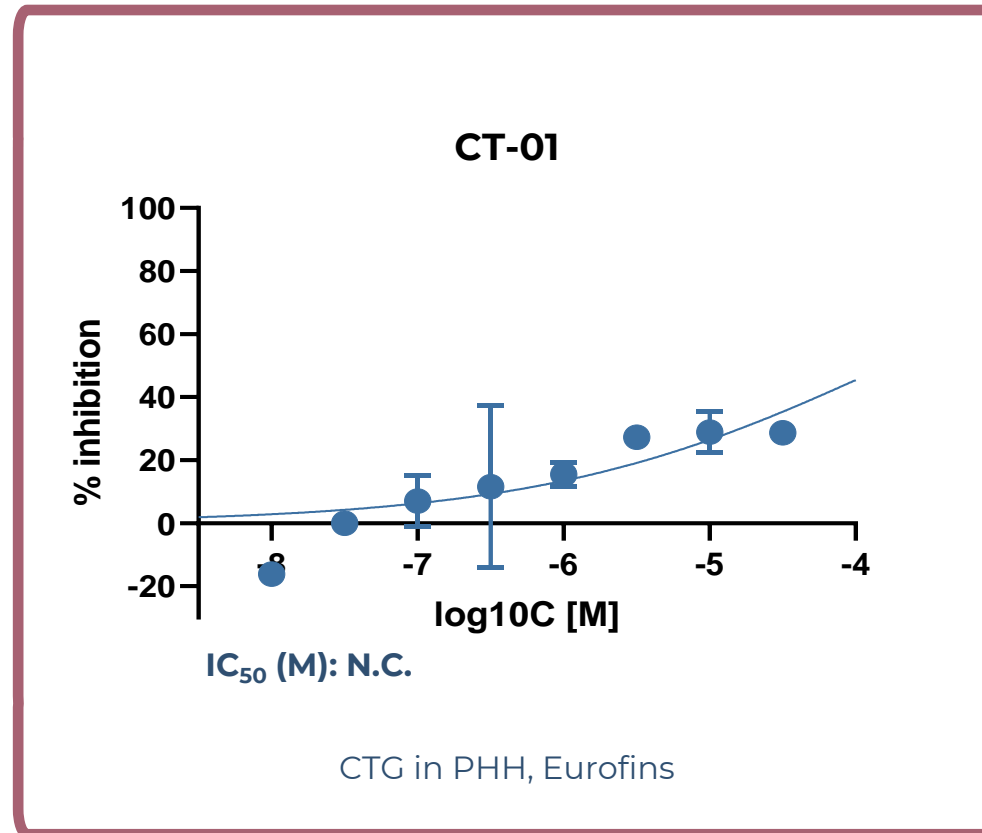

Highly potent CT-01 regresses tumors in mice

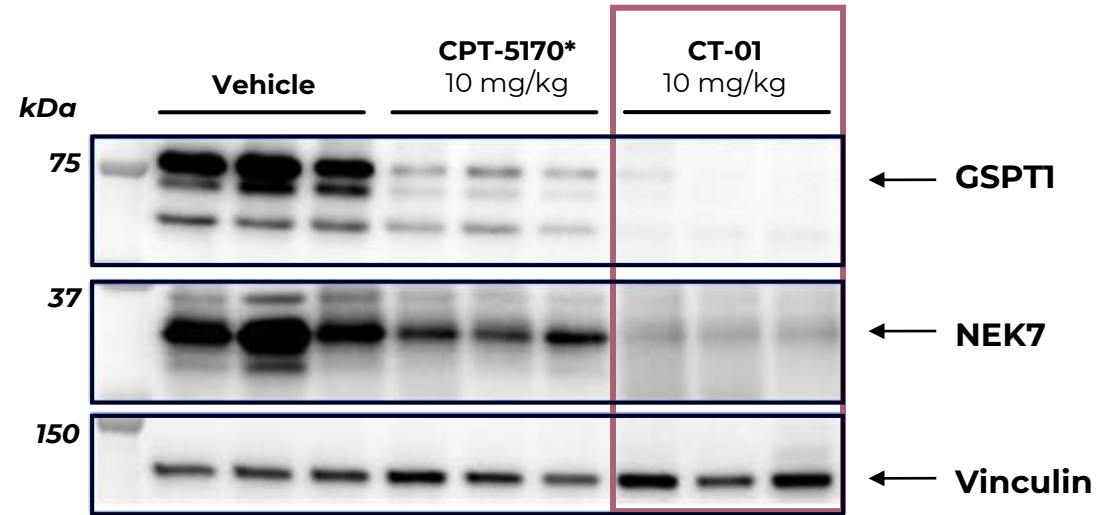
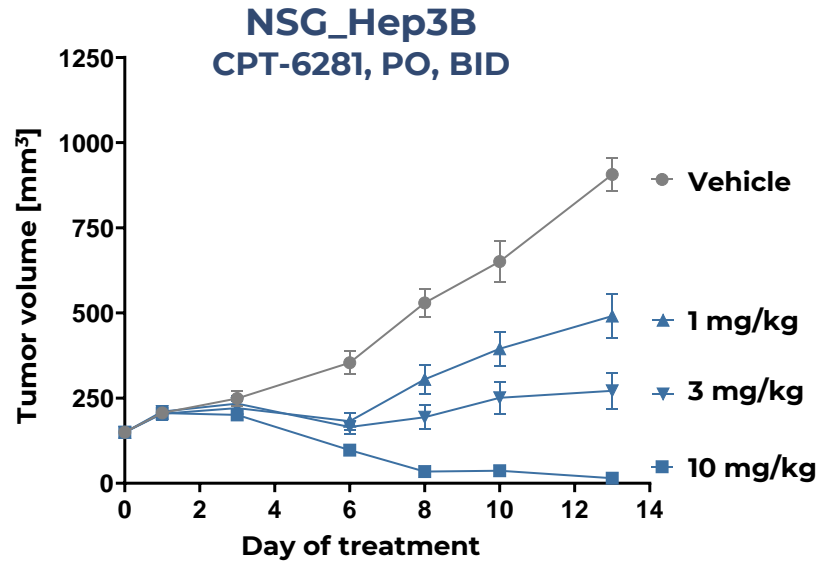

Regression of large tumors (~ 150 mm²) observed at doses as little as 10 mg/kg BID administered orally
*CPT-5170: an early lead compound in the CT-01 project

CT-01 strongly regresses liver cancer in Hep3B model at 10 mpk

Convincing tumor growth inhibition in HCC PDX models



CrownBio
CONNECTING SCIENCE TO PATIENTS

PDX Models/

10 random HCC patient samples (no selection for drug target)
CT-01, 100mg/kg, BID
3 animals per vehicle & treatment groups

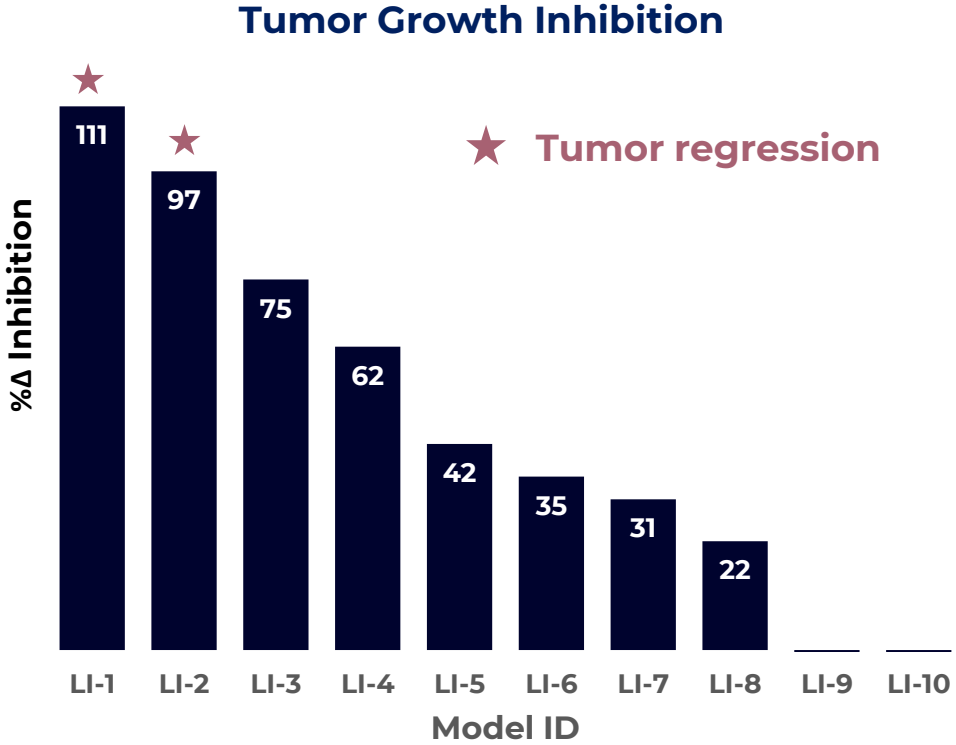

Efficacy demonstrated in 8/10 PDX models; TGI>50% in 4 models, 2 models with regression

Strong synergy of CT-01 in combination with everolimus



PDX Models/



Everolimus is an approved anticancer drug (kidney, breast & brain cancers), and shows clear synergy with CT-01 in combination

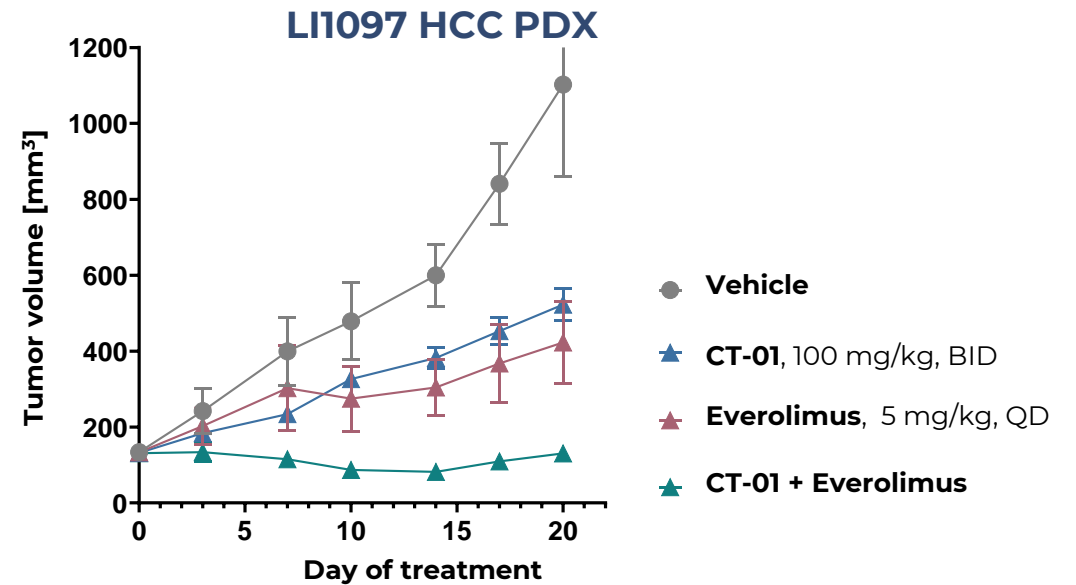
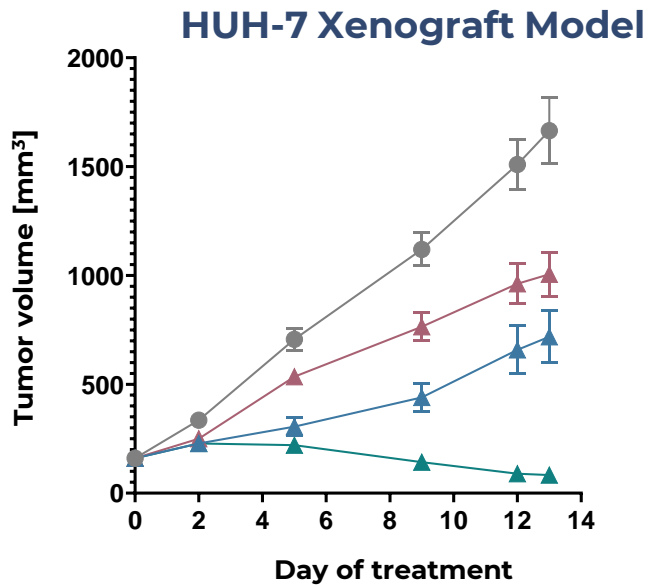

Combination with everolimus sensitizes poorly or non-responding tumor models

CT-01 is highly differentiated among GSPTI degraders

Assay	CT-01 (Captor) ¹	CC-90009 (BMS) ²	MRT-2359 (Monte Rosa) ³
Selectivity (Px, WB)	GSPT1, GSPT2, NEK7	GSPT1, GSPT2, SALL4, FIZ1, RNFI66, ODC1 (1)	GSPT1, GSPT2
CYP DDI (2B6, 1A2, 2D6, 3A4, 2C8, 2C9, 2C19)	>50 µM	CYP2C19 at 1.5 µM	>30 µM
hERG	>30 µM	5.3 µM	>30 µM
CEREP, % inhibition	Protein panel <20% at 10 µM	M1/M2 > 50% at 10 µM	a1A>50% at 10 µM
Caco2 (Efflux Ratio) of active drug	1.0	>100	9
Route of Administration	PO	IV	PO
Metabolic activation	Yes	No	No
Cell permeability of the active drug	Very low	High	High
Clearance of the active drug	Fast; >300 ml/min/kg	Medium; ~70 ml/min/kg	N/A
Tissue specificity	Yes	No	No
Potential weaknesses	Unknown (No hypocalcemia or thrombocytopenia seen in GLP-tox)	Hypocalcemia and thrombocytopenia	Dose-limiting thrombocytopenia

(1) Internal profiling
(2) DOI: 10.1021/acs.jmedchem.0c01489
(3) [Monte Rosa Corporate Presentation](#)

CC-90009 = BMS / Celgene GSPTI

CT-01 (GSPTI)

CT-01: CTA submission status

In vitro and *in vivo* pharmacology studies



Drug Substance synthesis optimization and manufacture in large scale



DMPK studies



Preliminary toxicology studies in 2 animal species



Toxicology studies under GLP (GLP Tox)



Drug Substance GMP manufacture



Drug Product – capsule preparation



CTIS (Clinical Trial Information System) package preparation and submission



Clinical Trial Application Assessment



Study design

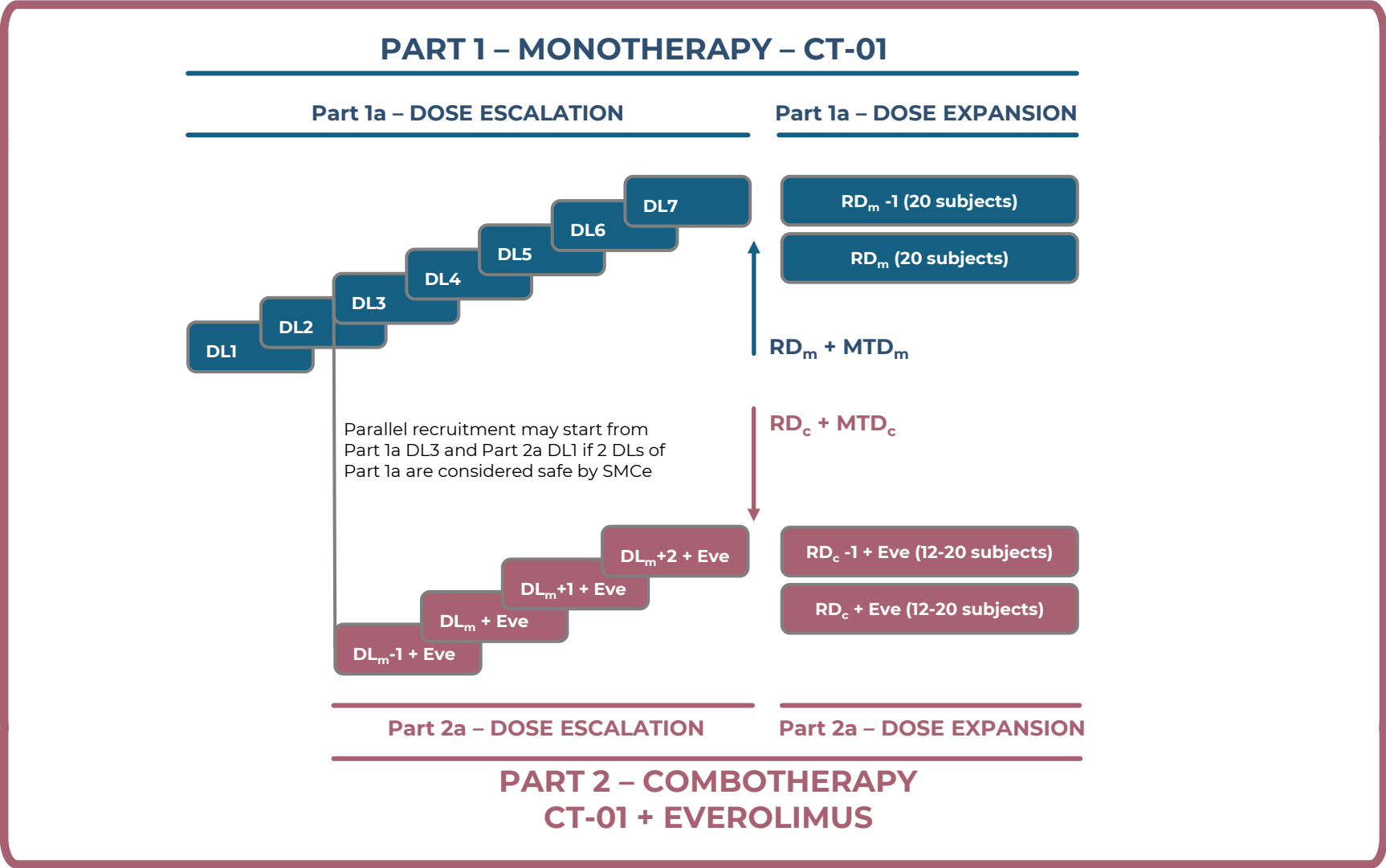

Best-in-class potential of highly differentiated CT-01

- **Strong differentiation from other GSPTI degraders (BMS, Monte Rosa)**
 - Best-in-class degradation profile
 - Active degrader lingers inside cancer cells after activation (poor cell penetration after prodrug conversion)
 - Active degrader is rapidly cleared from systemic circulation
- **Degradation profile**
 - GSPTI, NEK7
 - Activated in diseased liver, lung, adipocytes and inflamed blood-brain barrier
- **Initial indications**
 - hepatocellular carcinoma (HCC)
 - lung cancer
 - brain tumors
 - rare cancers (hepatoblastoma, lipo- and angiosarcoma)
- **Development activities**
 - Clinical Trial Authorization Application submitted in Europe
 - Initiation of Phase 1 clinical trials in hepatocellular carcinoma Q1 2025

CT-03: First-in-Class MCL-1 Degraders for Liquid & Solid Tumors

CT-03: MCL-1 – a critical pathway for cancer resistance

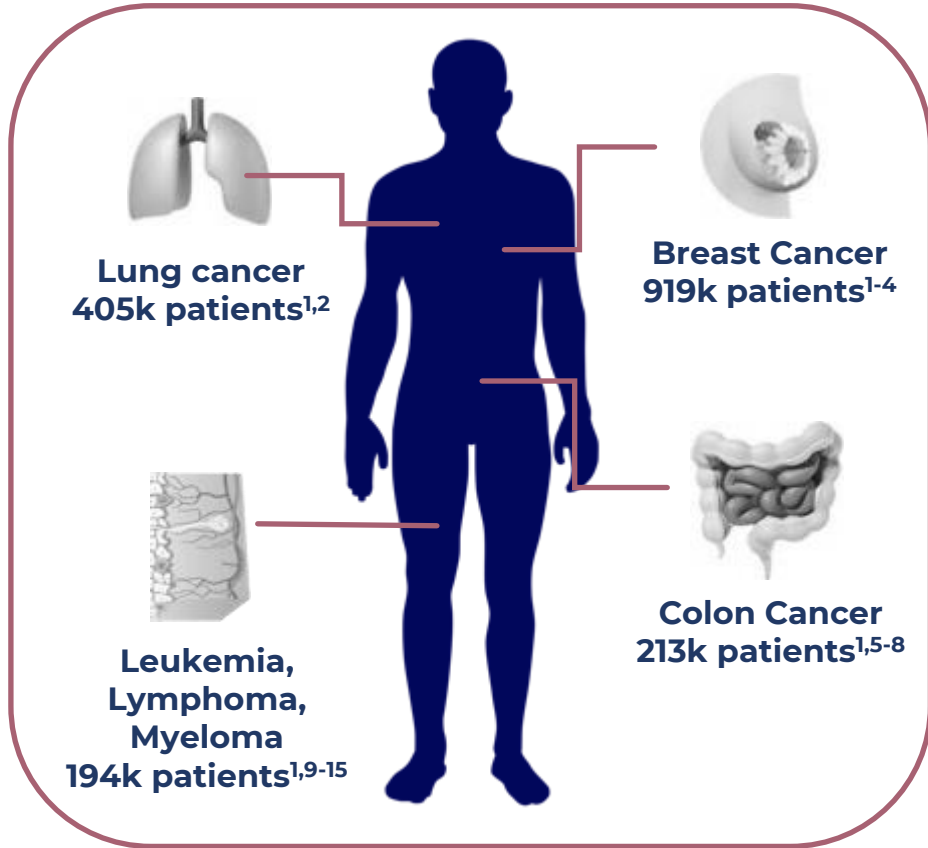

MCL-1 is one of the most amplified proteins in cancer[†]

A critical resistance mechanism in hematological and solid tumors[‡], cancer cells require very high levels to avoid induction of apoptosis

Degradation or inhibition of MCL-1 protein directly attenuates tumors in vivo as monotherapy & sensitizes tumors for other therapies

Inhibitors require prolonged, almost 100% of target coverage and cause accumulation of MCL-1[†], cardiotoxicity through necrosis[§]

Short-term degradation of $\approx 70\%$ of MCL-1 irreversibly induces apoptosis in cancer cells

This, together, with optimized clearance expands the therapeutic window of degraders

1. <https://gco.iarc.fr/today/en/>
2. Semin Cancer Biol. 2006 16(4):253-64
3. Cell Death Dis 2018 9(2): 19
4. Breast Cancer Res. 2016 18(1): 125
5. Int J Mol Sci. 2019 20(3): 5999

6. Cell Death Dis. 2022 13(1): 63
7. Colorectal Dis 2022 24(11): 1295-1307
8. Ann Fam Med. 2016 14(3): 215-20
9. Exp Hematol Oncol. 2020 Jun 19;9:14
10. Hum Pathol. 2004 Sep;35(9):1095-100

11. ACS Key Statistics for AML, CLL, Lymphoma
12. Curr Treat Options Oncol. 2020 Jun 29;21(8):66
13. Int J Mol Sci. 2024 Jan 27;25(3):1589
14. Blood Rev. 2020 Nov;44:100672
15. Leukemia. 2013 Jun;27(6):1381-90

[†]Front Oncol. 2023 Jul 31;13:1226289
[‡]Apoptosis. 2023 Feb;28(1-2):20-38
[§]Science. 2020 April; 23(4): 101015

CT-03: MCL-1 – a critical pathway for cancer resistance

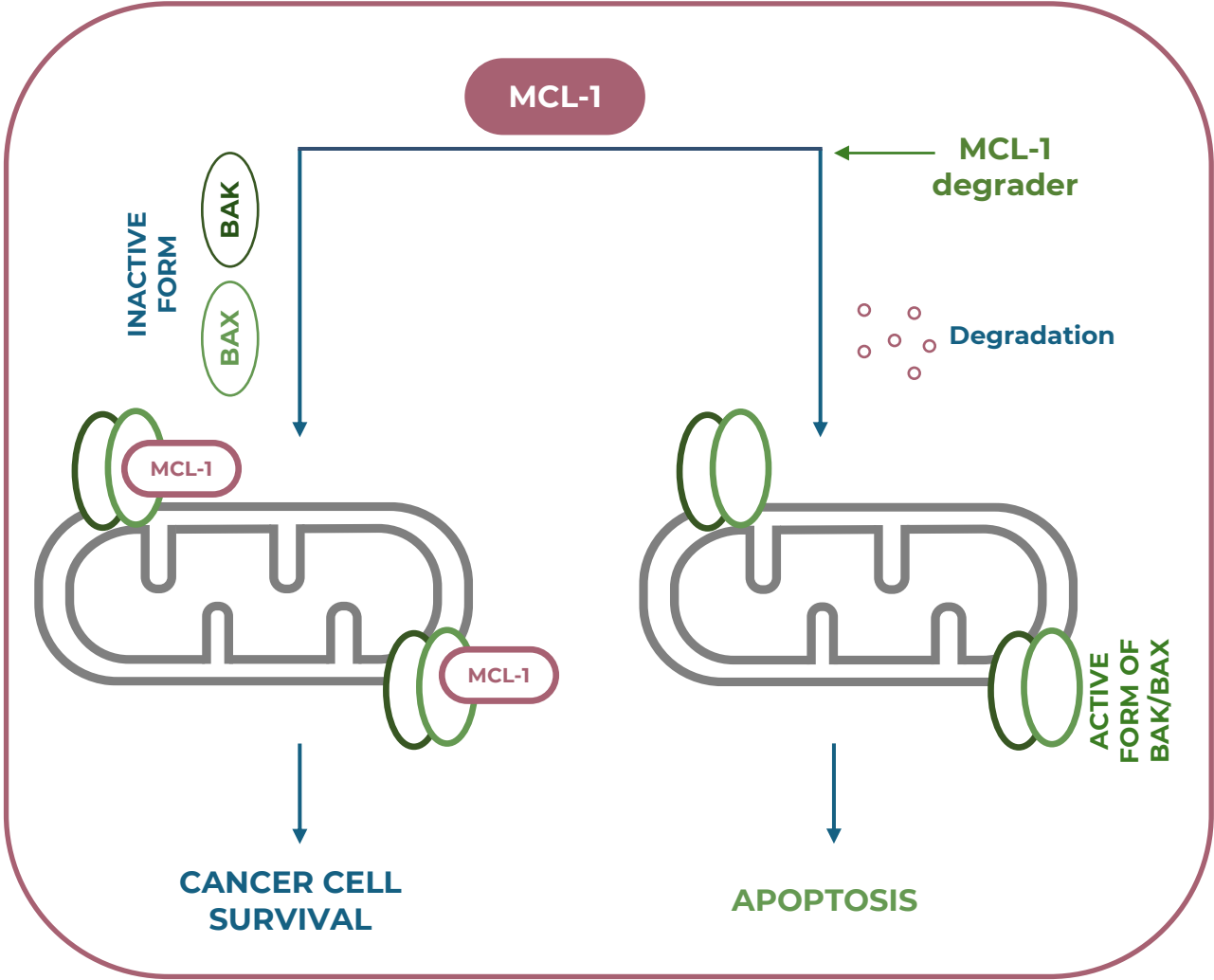

MCL-1 biology and clinical relevance

MCL-1 is a well-characterized oncogenic protein with a key role in **evading apoptosis** and **promoting the survival of cancer cells**¹.

Studies show cell growth dependency of MCL-1 levels in liquid (leukemia, lymphoma, myeloma) and solid tumors (breast and lung cancers²).

Monoallelic KO of MCL-1 in mice is viable and do not show signs of cardiac damage³ or gross phenotype, and show resistance to selected liquid tumors.

Numerous systemic and targeted therapies drive the clonal selection of cells towards increased levels of MCL-1, like in AML refractory to venetoclax⁴.

1. Singh R et al. Nature Reviews, 2019; 20: 175-193
2. Kotschy A et al. Nature, 2016; 538(7626): 477-482
3. Brinkmann K et al. Cell Death Differ, 2017; 24(12): 2032-2043
4. Garcia S et al. Cancers, 2024; 16(6): 1091

CT-03: MCL-1 – a critical pathway for cancer resistance

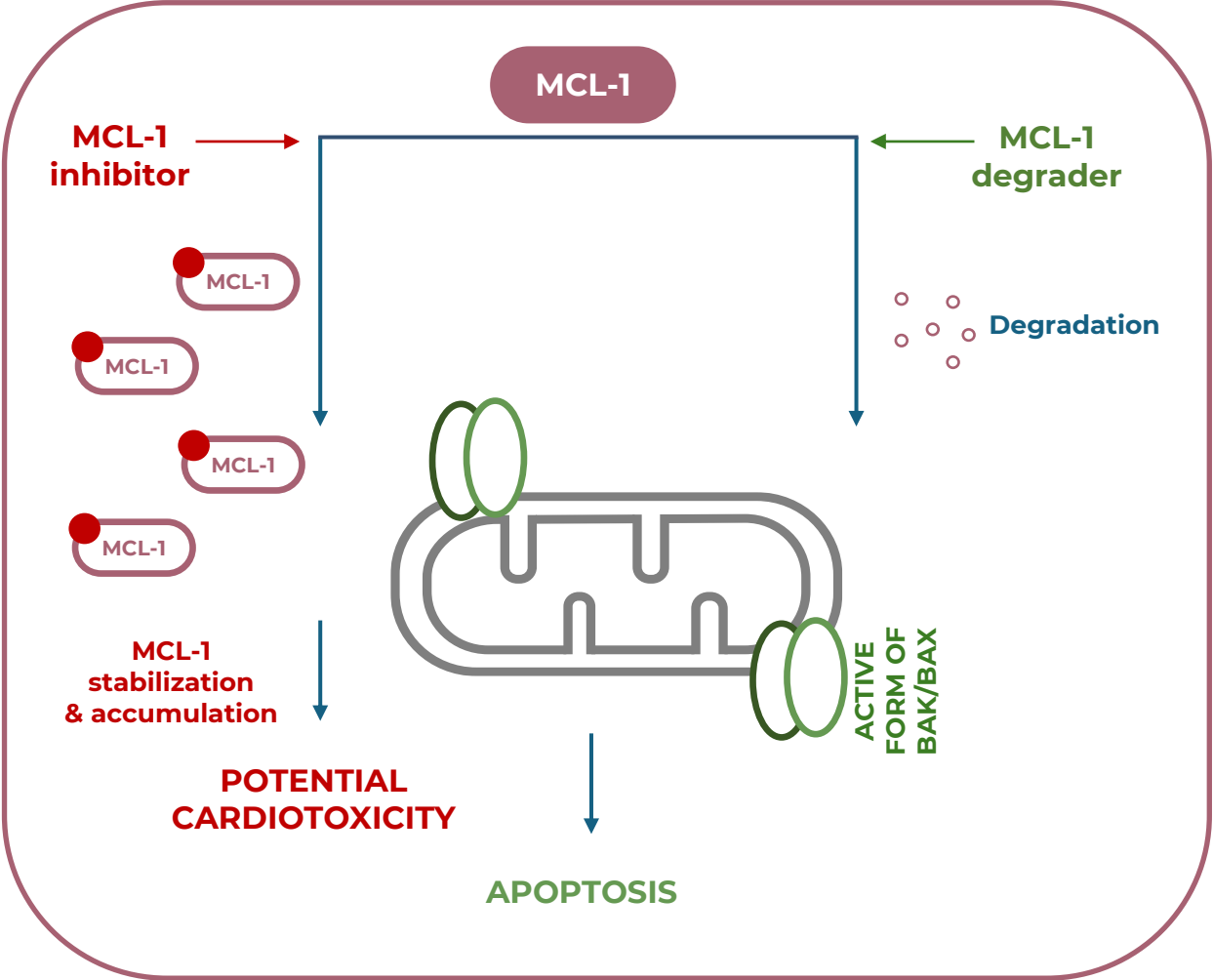

MCL-1 degraders advantage over inhibitors

MCL-1 inhibition increases its stability, through its aberrant phosphorylation and consequent accumulation¹.

The result of MCL-1 accumulation is a cellular rewiring that affects cardiomyocyte viability *via* necrosis, not apoptosis².

None of the MCL-1 inhibitors progressed significantly in clinical development due to safety issues, i.e. cardiotoxicity.

Since degraders induce rapid apoptosis of cancer cells via reduction of MCL-1 levels and provide homeostatic levels of MCL-1 in cardiac myocytes, they are expected to avoid toxicity seen with the class of inhibitors.

1. Singh R et al. Nature Reviews, 2019; 20: 175-193
2. Kotschy A et al. Nature, 2016; 538(7626): 477-482

MCL-1: a high potential cancer target

Highly attractive target with application in numerous cancer markets

Hematological malignancies

Multiple Myeloma (MM)
Est. \$53B by 2030¹

Acute Myeloid Leukemia (AML)
Est. \$6B by 2028²

Non-Hodgkin Lymphoma (NHL)
Est. \$16B by 2032³

Selected solid tumors

Small cell lung cancer (SCLC)
Est. \$6.5B by 2031⁴

Non-small cell lung cancer (NSCLC)
Est. \$36.9B by 2031⁵

Triple-negative breast cancer (TNBC)
Est. \$1.5B by 2030⁶

Despite years of effort, no MCL-1 targeting drug has been approved and several inhibitors have been associated with toxicity

Captor has nominated a candidate, CT-03p (prodrug); neither has shown any evidence to date of cardiotoxicity in keeping with their different mode of action

¹Allied Market Research
²BCC Research
³Spherical Insights

⁴HealthcareAnalyst
⁵Allied Market Research
⁶Databridge Market Research

High potency of MCL-1 degraders in AML patient samples *ex vivo* & *in-vivo* leukemia model

MCL-1 degrader is more potent than MIK665 (Novartis) in patient-derived AML cells

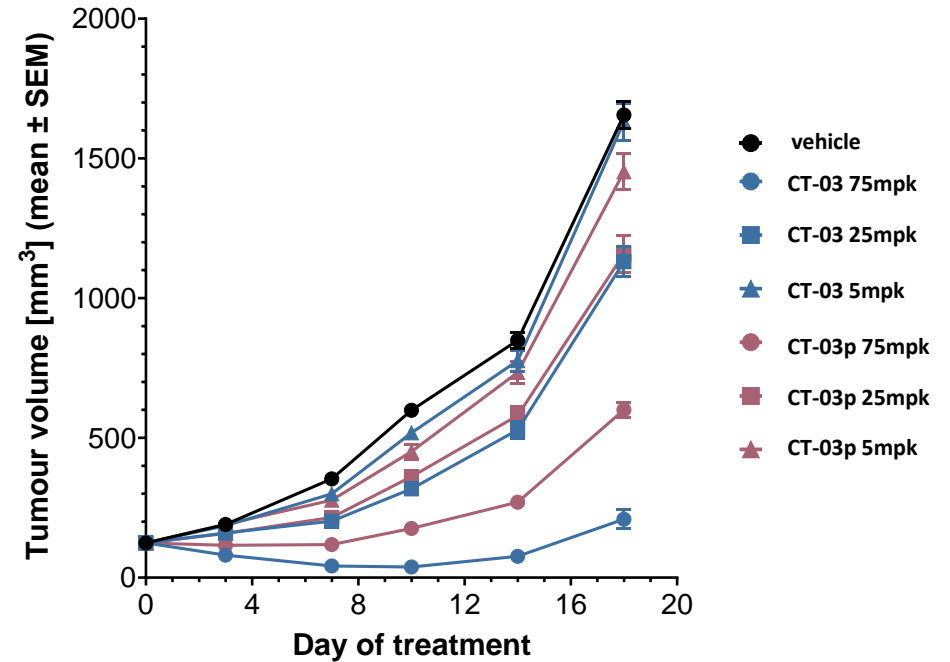
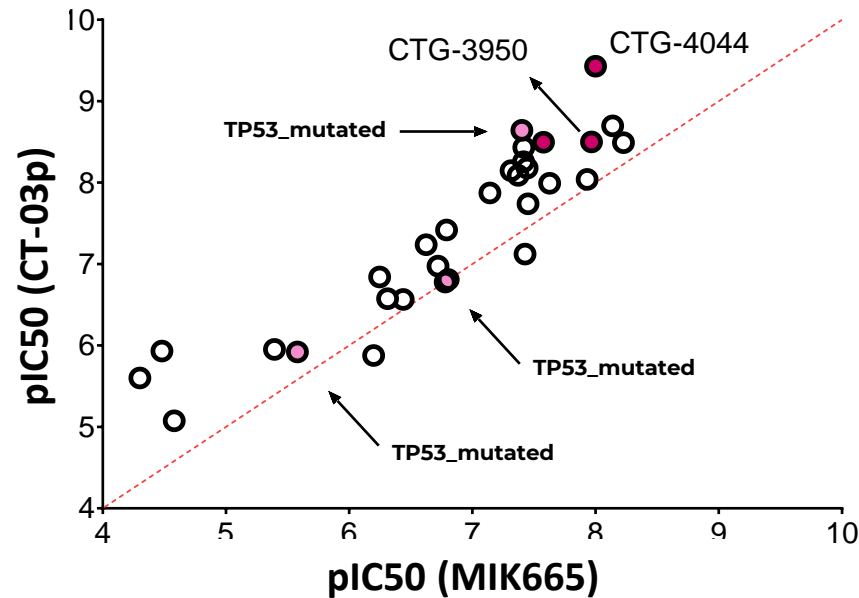

Q3D, IV
N=7-10/group

CT-03 – active compound; CT-03p – prodrug of CT-03

CT-03p (prodrug) is more potent than MIK665 (Novartis) in a panel of 30 PDC cell lines and shows nM activity in cells refractory to gilteritinib and venetoclax

Combined of MCL-1 degrader with venetoclax regresses AML tumors in mice

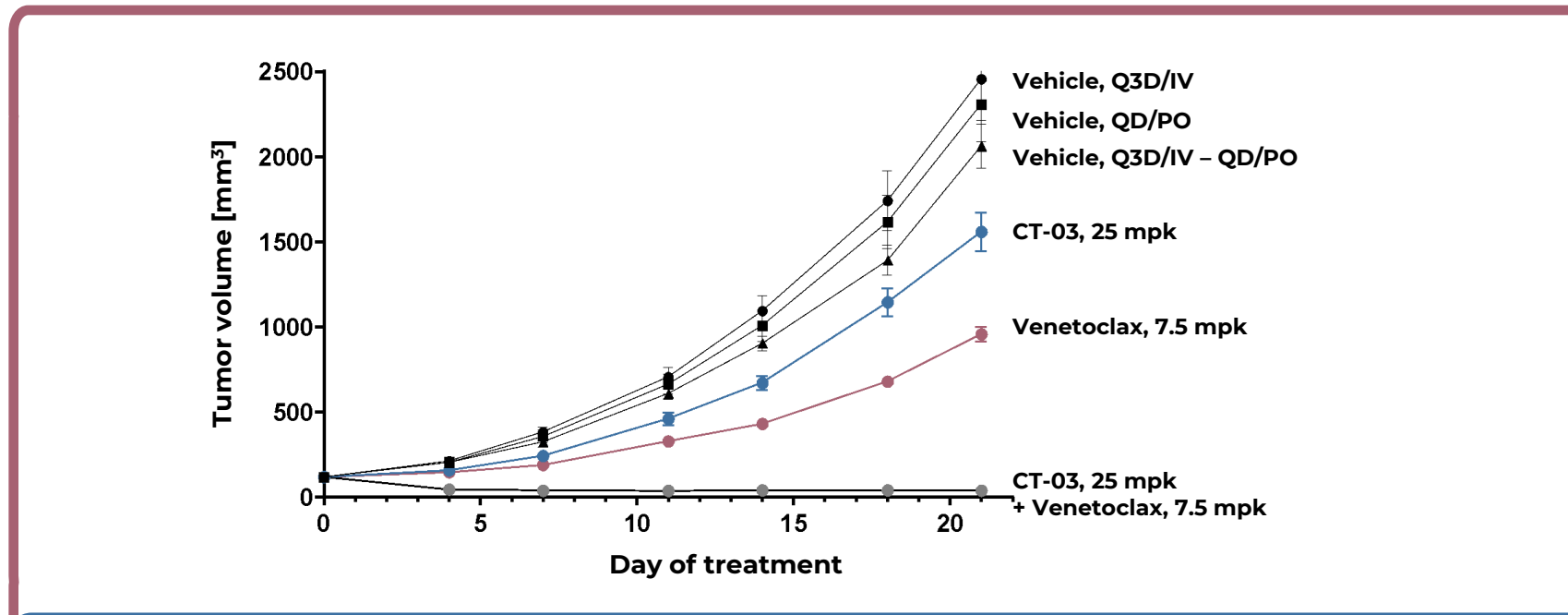

Regression of large tumors was observed for both CT-03 and venetoclax, with the combination providing the best outcome

CT-03 was administered 8 times, every 3 days (Q3D) intravenously and venetoclax was administered daily (QD) orally

CT-03 in combination with venetoclax strongly inhibits cancer growth in MV4-11 Human Leukaemia Xenograft Model

Degradation of MCL-1 in NHP after single IV dose of degraders

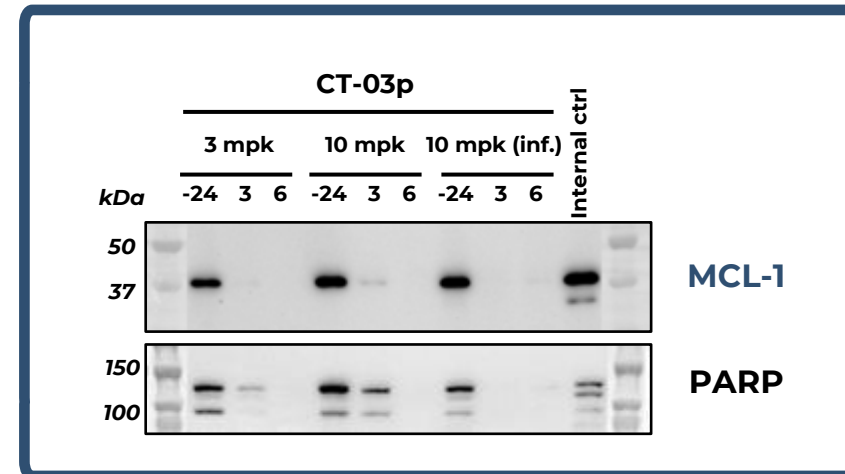
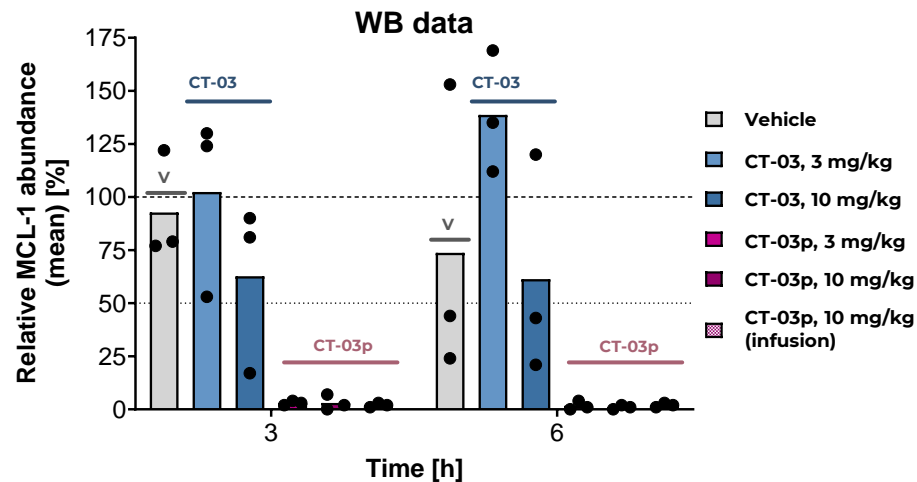
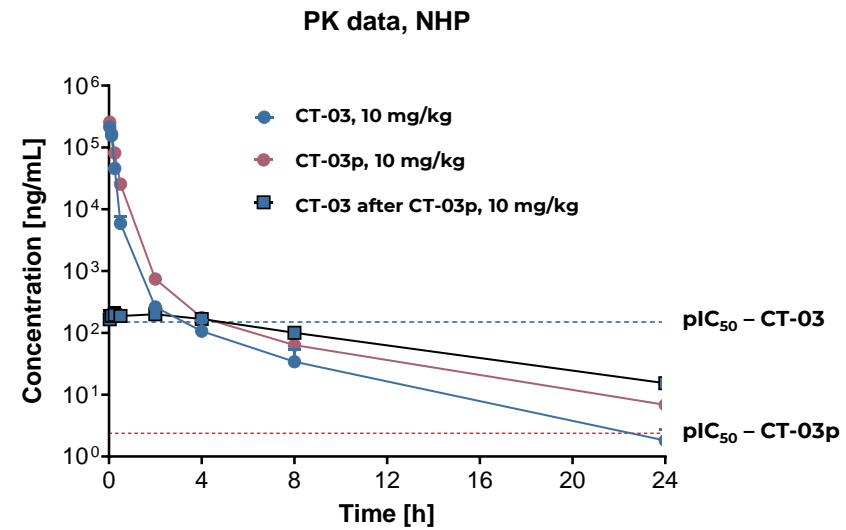
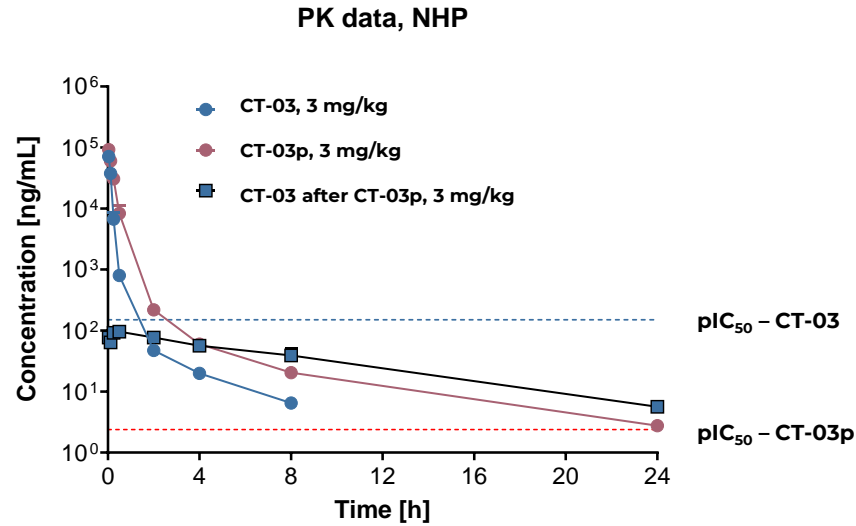

Cardiotoxicity marker Troponin I in plasma of NHPs after CT-03 dosing

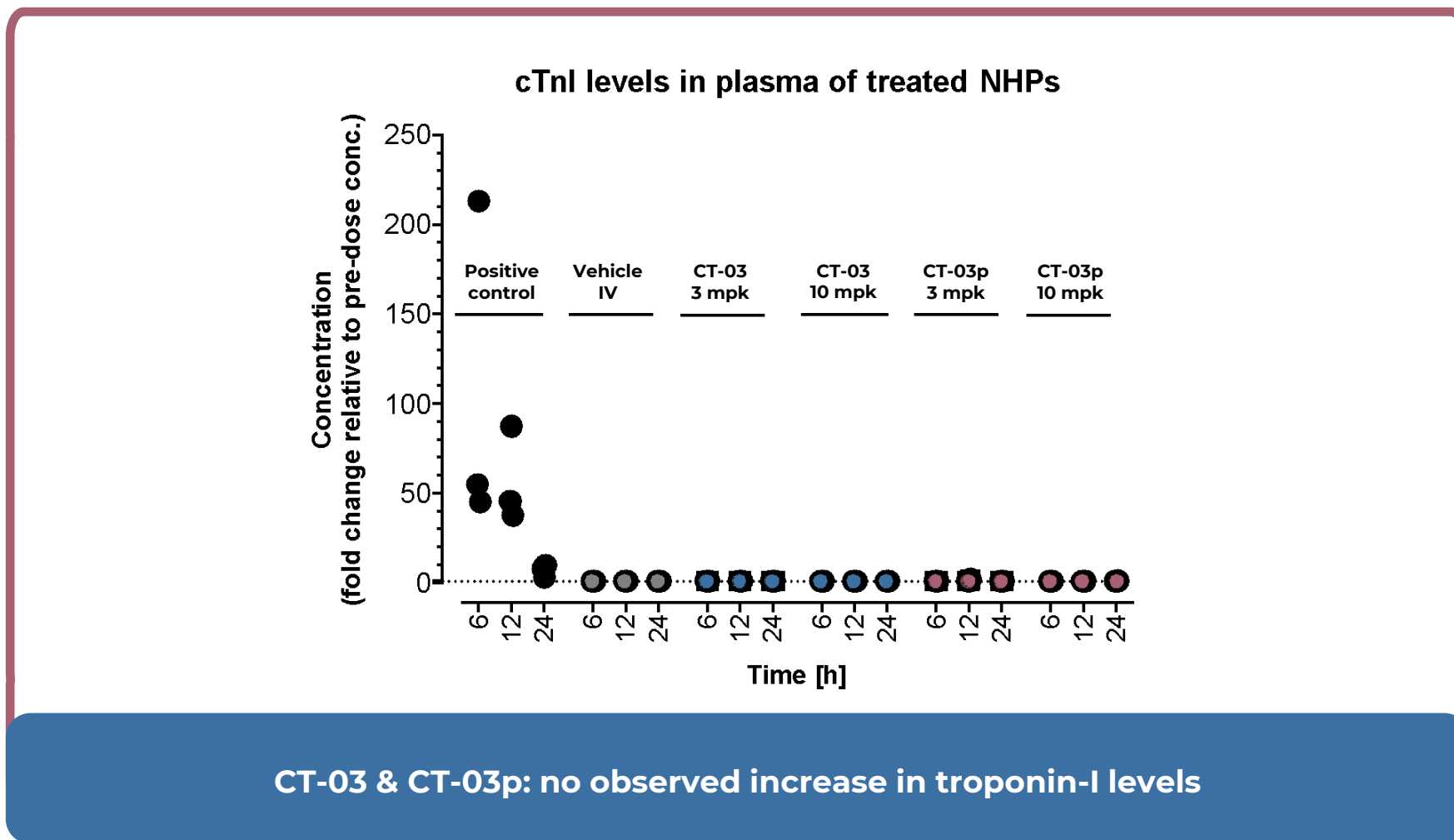

*Cardiotoxic positive control - Isoproterenol 3mg/kg, Vasopressin 0.3mg/kg
CT-03 – active compound; CT-03p – produg of CT-03

CT-03 candidate drug with unmatched therapeutic window

- **Strong differentiation from MCL-1 inhibitors**

- Pharmacology of MCL-1 degradation vs. pharmacology of accumulation (inhibitors)
- No accumulation of MCL-1 protein
- No cardiotoxicity observations in MTD, DRF in NHPs by any means
- Very high degradation potency in mouse models, in NHP and in human cells *ex vivo*
- **Candidate drug in place**

- **Initial indications**

- Hematological cancers
- Solid tumors

- **Expected milestones**

- IND-enabling studies completion in H2 2025

**CT-02: First-in-Class NEK7 Degraders for
Autoimmune (CT-02S),
Neuroinflammation & Obesity (CT-02B)**

Significant market opportunities for Captor's NEK7 degraders

CT-02S
CPT-635(r)

Peripheral autoimmunity

NEK7 degraders could be used in combination with available therapeutics to manage comorbidities

Three significant therapeutic areas:

Obesity/ Metabolic

16% living with obesity worldwide⁵

\$100B¹

Autoimmune

5-10% of global population⁶

\$10.9B²

Cardiovascular

19.8M deaths in 2022 due to CVD⁷

\$152.6B³

Global market size (2030):

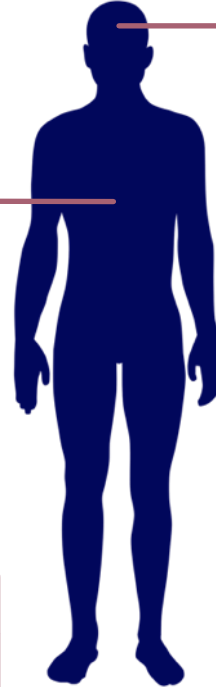

CT-02B
CPT-732(r)

Neurodegenerative diseases

Growing evidence for role of pathological activation of innate immunity in the pathogenesis of NDDs
Limited treatment strategies available: opportunity to target neuroinflammation via NEK7 degradation & inhibit disease progression

Alzheimer's: 35.8M patients worldwide¹⁰

Parkinson's: 8.5M patients worldwide (2019)¹¹

Multiple Sclerosis: 2.8M patients worldwide¹²

Huntington's: 400,000 patients worldwide⁸

ALS: 362,000 patients worldwide⁹

NDD market size is estimated to reach \$75B⁴ by 2030

1. <https://www.goldmansachs.com/intelligence/pages/anti-obesity-drug-market.html>

2. <https://www.databridgemarketresearch.com/reports/global-autoimmune-disease-treatment-market>

3. <https://www.researchandmarkets.com/report/cardiovascular>

4. <https://www.researchandmarkets.com/report/neurodegenerative-disease-drug>

5. <https://www.who.int/news-room/fact-sheets/detail/obesity-and-overweight>

6. J Autoimmun. 2010 May;34(3):168-77.

7. J Am Coll Cardiol. 2023 Dec 19;82(25):2350-2473

8. <https://pubmed.ncbi.nlm.nih.gov/36161673/>

9. <https://pubmed.ncbi.nlm.nih.gov/31797084/>

10. <https://www.who.int/news-room/fact-sheets/detail/dementia>

11. <https://www.who.int/news-room/fact-sheets/detail/parkinson-disease>

12. Mult Scler. 2020 Dec;26(14):1816-1821

NEK7 as a new target of the NLRP3 inflammasome pathway

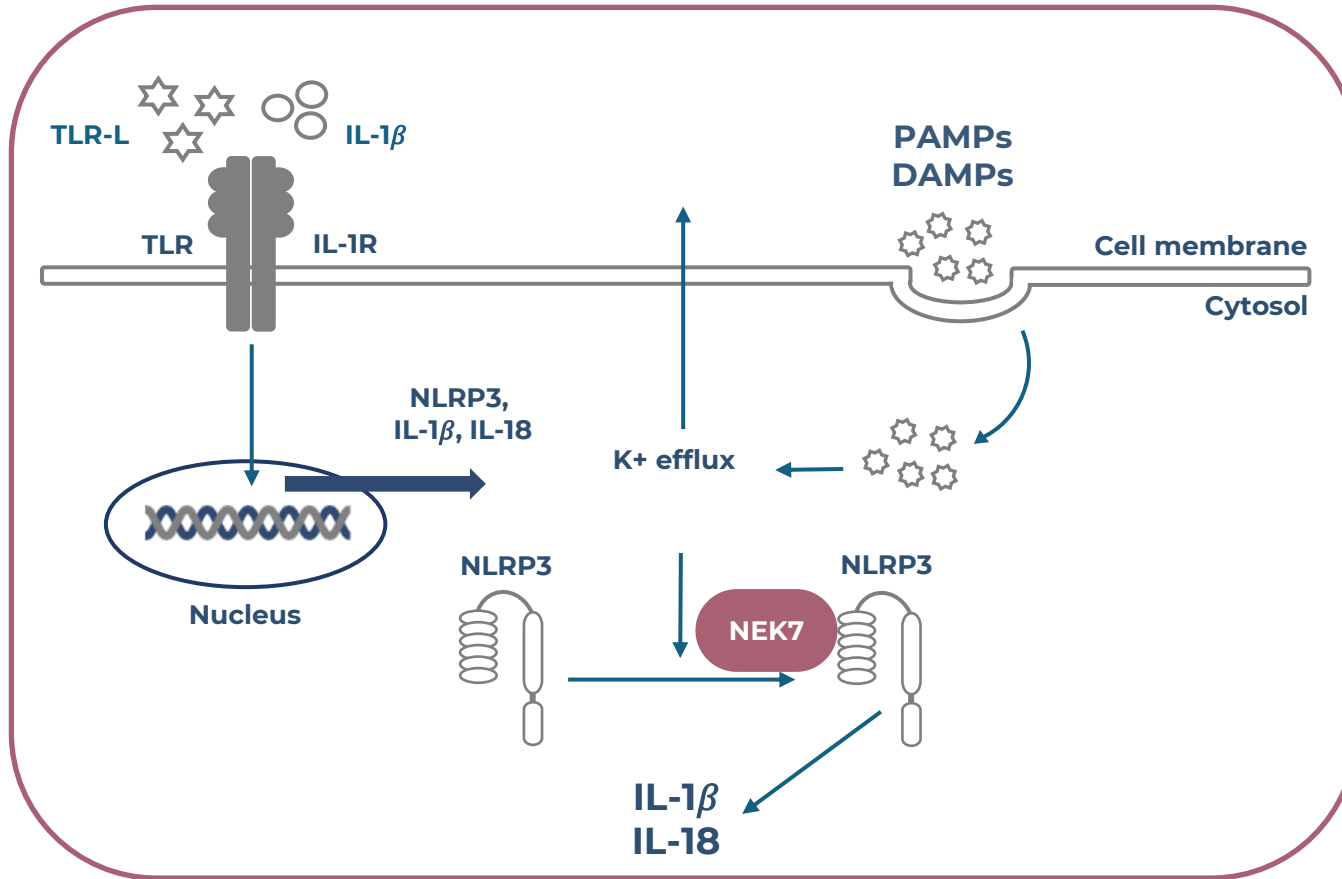

NEK7 overview

NEK7 is master regulator of the NLRP3 inflammasome complex through its scaffolding function

NEK7 KO/KD in mouse abrogates production of IL-1 beta in response to stimulating factors.

Haploinsufficient, NEK7^{+/-} mice show no internal anatomical or growth abnormalities.

Antagonists of IL-1β or IL-1R are approved in:

- CAPS syndromes (FCAS, MWS, NOMID)

- inflammatory disorders, e.g. familial mediterranean fever (FMF), tumor necrosis factor receptor associated periodic syndrome (TRAPS), hyperimmunoglobulin D syndrome (HIDS) / mevalonate kinase deficiency (MKD), Still's disease, and gouty arthritis.

Degradation of NEK7 inhibits the production of pro-inflammatory cytokines in *in vitro* models and halts disease progression in pre-clinical mouse models of chronic NLRP3-related diseases*.

1. Shi et al; Nature Immunology, vol 17 (2016);
 2. Sharif et al.; Nature, vol 570, (2019);
 3. He et al.; Nature, vol 530, (2016);
 4. Walle and Lamkanafi; Nature Reviews Drug Discovery vol 23
 *own results conducted by Captor Therapeutics

NEK7 as a new target of the NLRP3 inflammasome pathway

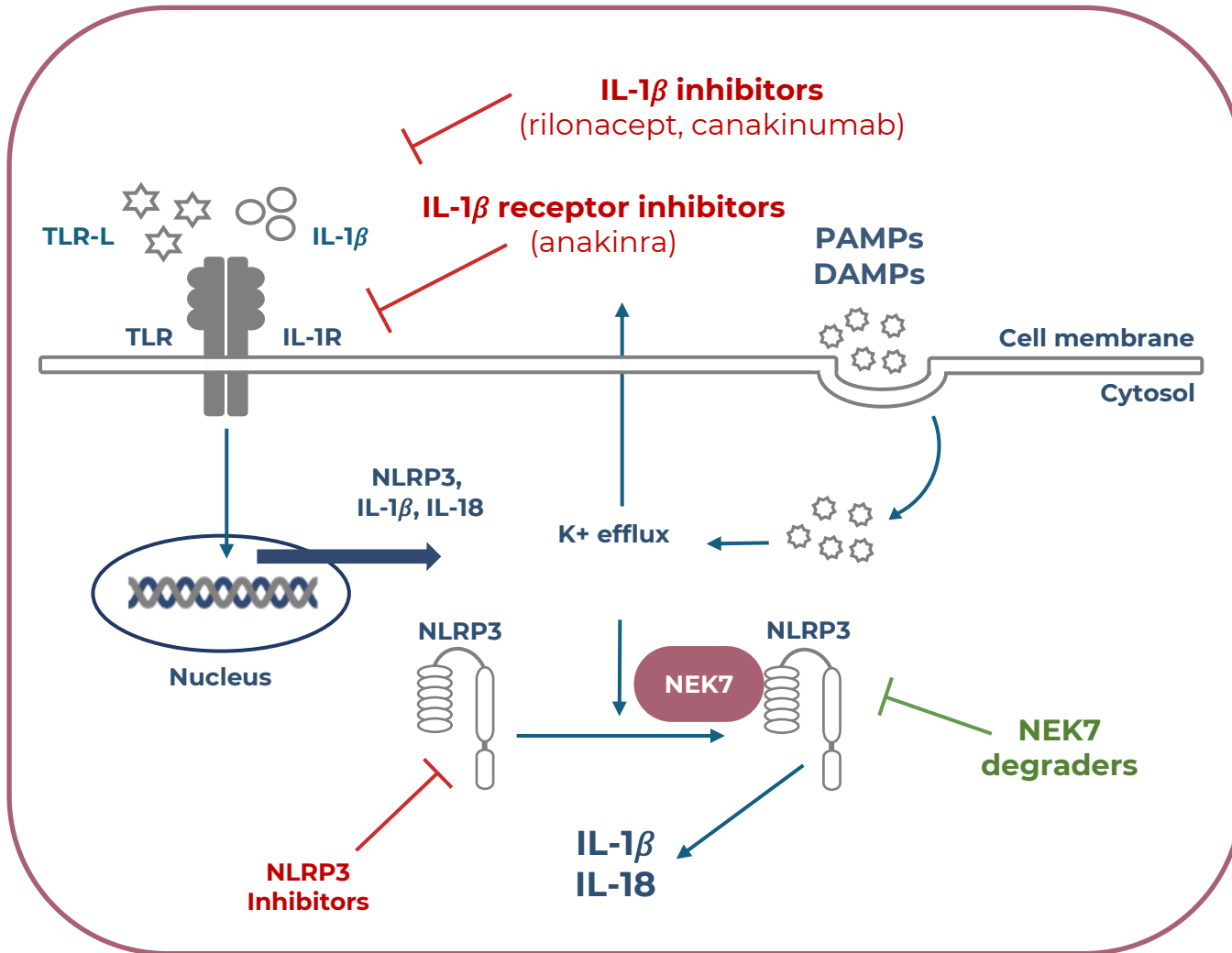

Differentiation

From anti-IL-1 β antagonists:

Once daily oral administration instead of injection

Uncoupling pharmacokinetics from pharmacodynamics potentially offers a better safety profile

From NLRP3 inhibitors:

Uncoupling pharmacokinetics from pharmacodynamics potentially offers a better safety profile and prolonged efficacy

High safety profile: due to multiple functions of NLRP3 outside of the inflammasome, there are serious safety concerns about NLRP3 inhibitors

Complete IL-1 β shutdown potentially manifests in recurring infections

NLRP3 requires high coverage by inhibitors, which is recapitulated in increased frequency of dosing (BID) of some of the clinical compounds, e.g. DFV890 (Novartis)

1. Molina-Lopez et al; Nature Communications, vol 15, (2024); <https://www.ema.europa.eu/en/medicines/human/EPAR/ilaris>

2. <https://www.ema.europa.eu/en/medicines/human/EPAR/kineret>

*own results conducted by Captor Therapeutics

Intervention in NLRP3 pathway via NEK7 degradation

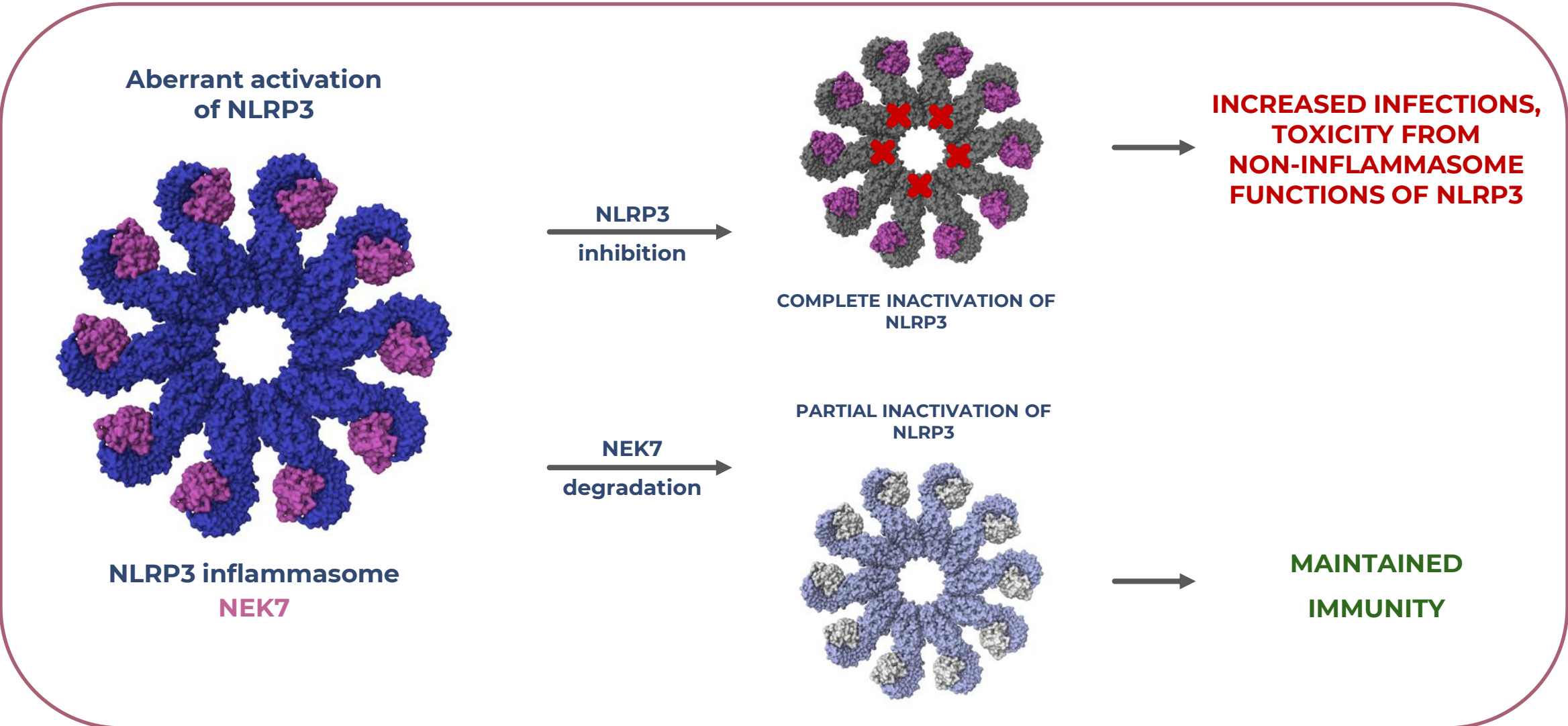

Potent degradation of NEK7 in human macrophages *in vitro*

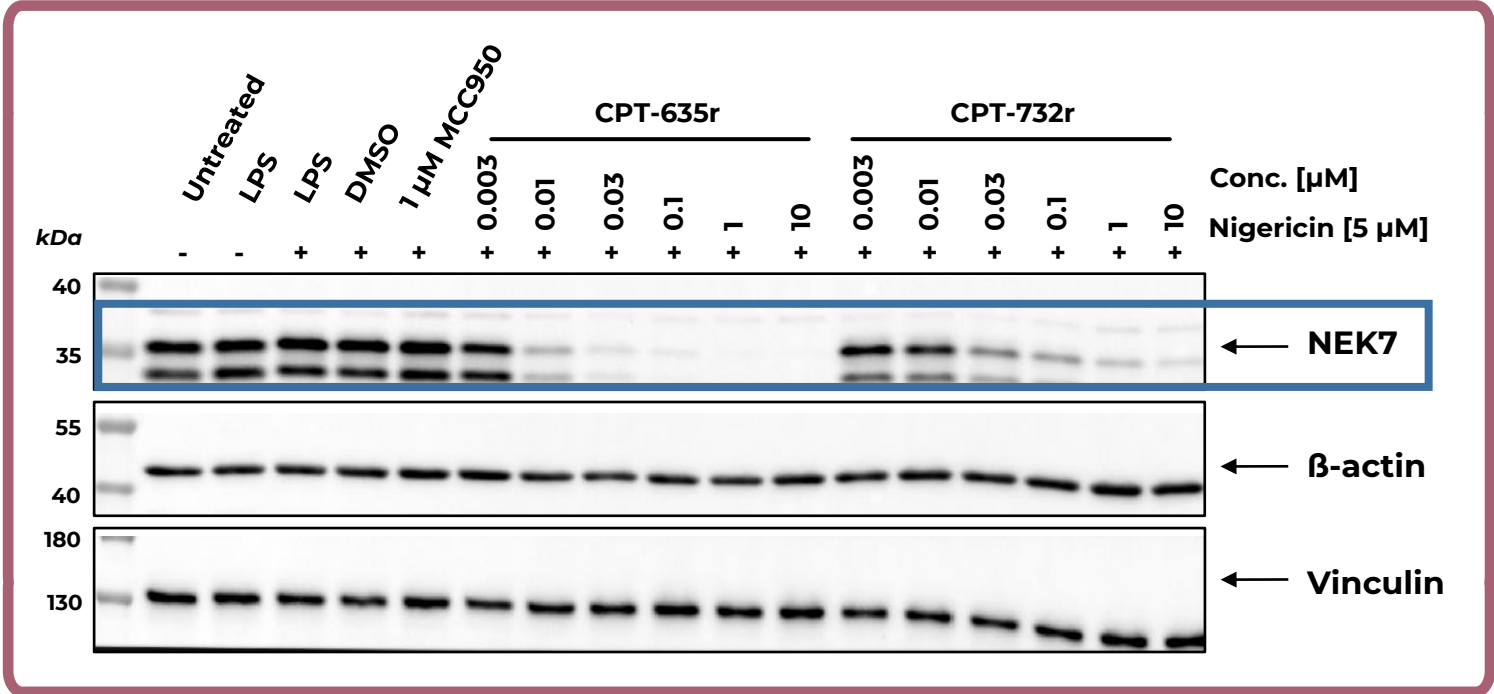

CPT-635r and CPT-732r degrade NEK7 protein dose-dependently in human PBMC-derived macrophages with LPS+Nigericin activated inflammasome

Human PBMC differentiated into macrophages with M-CSF; treatment with compounds – 24h; inflammasome activation: LPS – 3h, Nigericin – 1h
MCC950 – NLRP3 inhibitor (Roche/ Inflazome); CPT-635r – racemate of CPT-635, CPT-732r – racemate of CPT-732

High selectivity of NEK7 molecular glue degraders

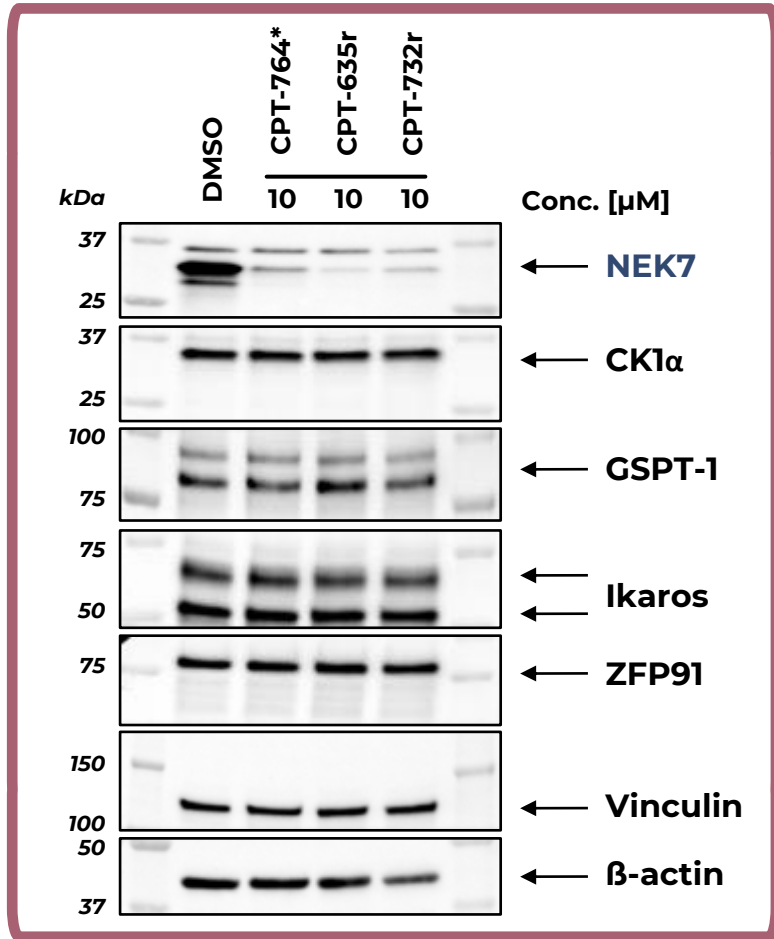

*Early lead compound

CPT-635r – racemate of CPT-635, CPT-732r – racemate of CPT-732

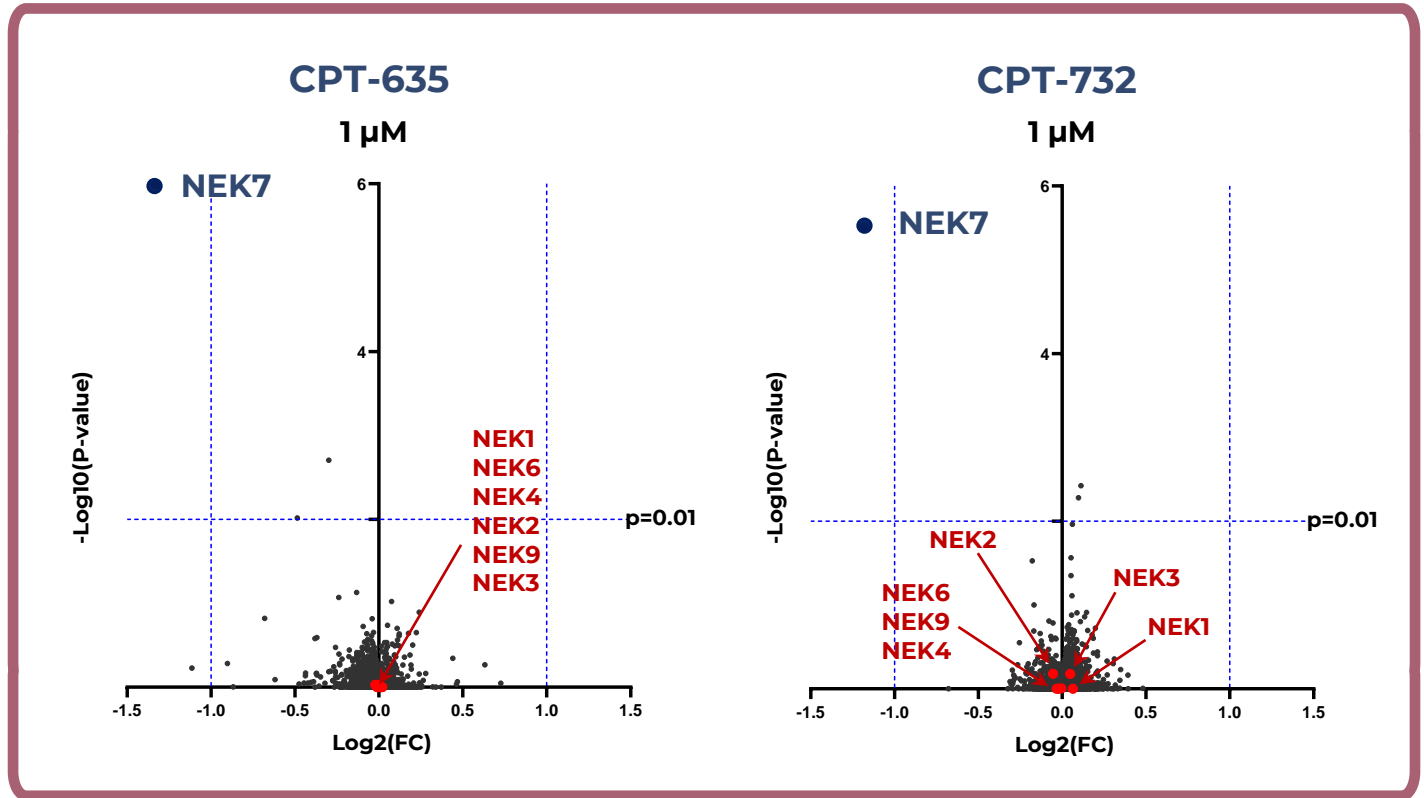

Confirmed degradation of NEK7 in hPBMCs
No off-targets, even at high doses

High selectivity of diastereoisomers against teratogenic targets

Kelly neuroblastoma cell line

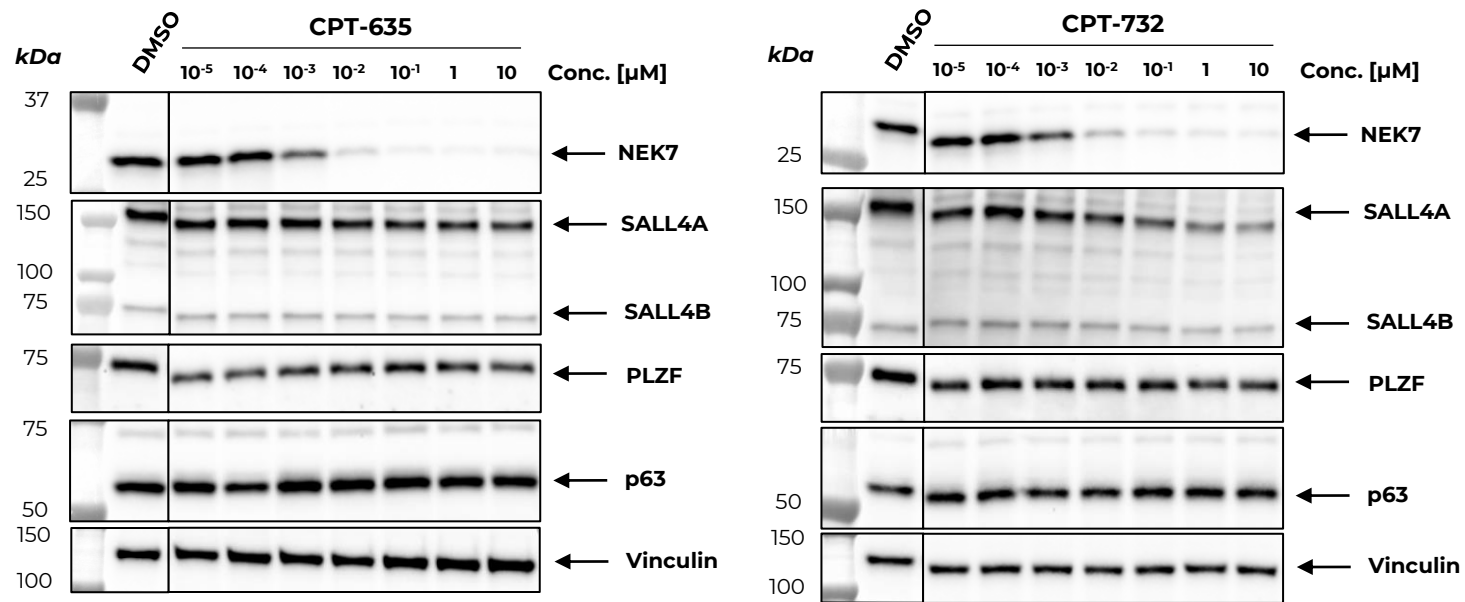

Cells were treated with the compounds for 24 hours.

High selectivity against off-targets suspected of teratogenicity: SALL4, PLZF and p63

Target	CPT-635		CPT-732	
	DC ₅₀	D _{max}	DC ₅₀	D _{max}
NEK7	0.809 nM	99.2%	2.77 nM	95.6%
SALL4A	>10 μM	39.2%	>10 μM	48.7%
PLZF	>10 μM	27.3%	>10 μM	30.1%
p63	>10 μM	29.4%	>10 μM	0%

CPT-635r efficiently covers & degrades NEK7 in NHPs after a single dose

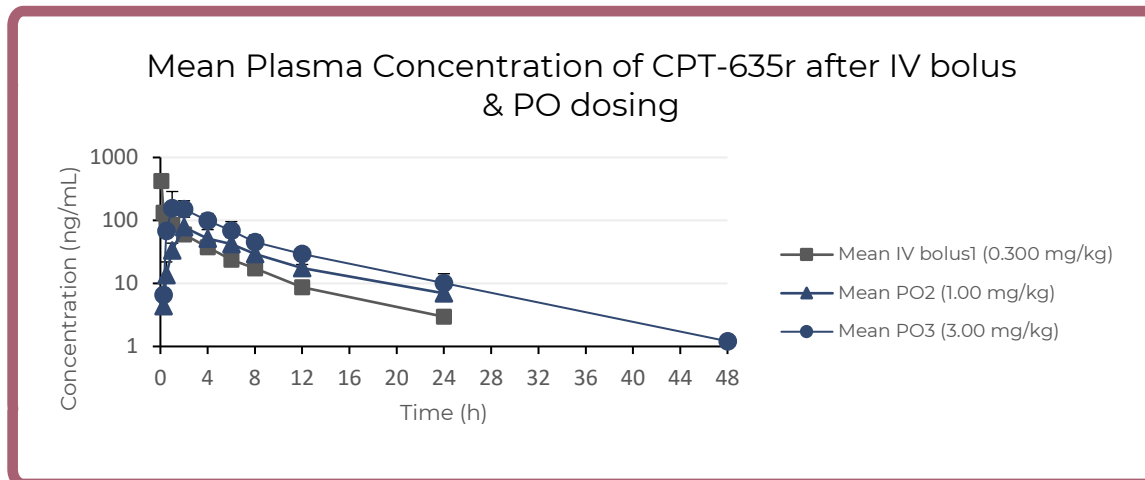
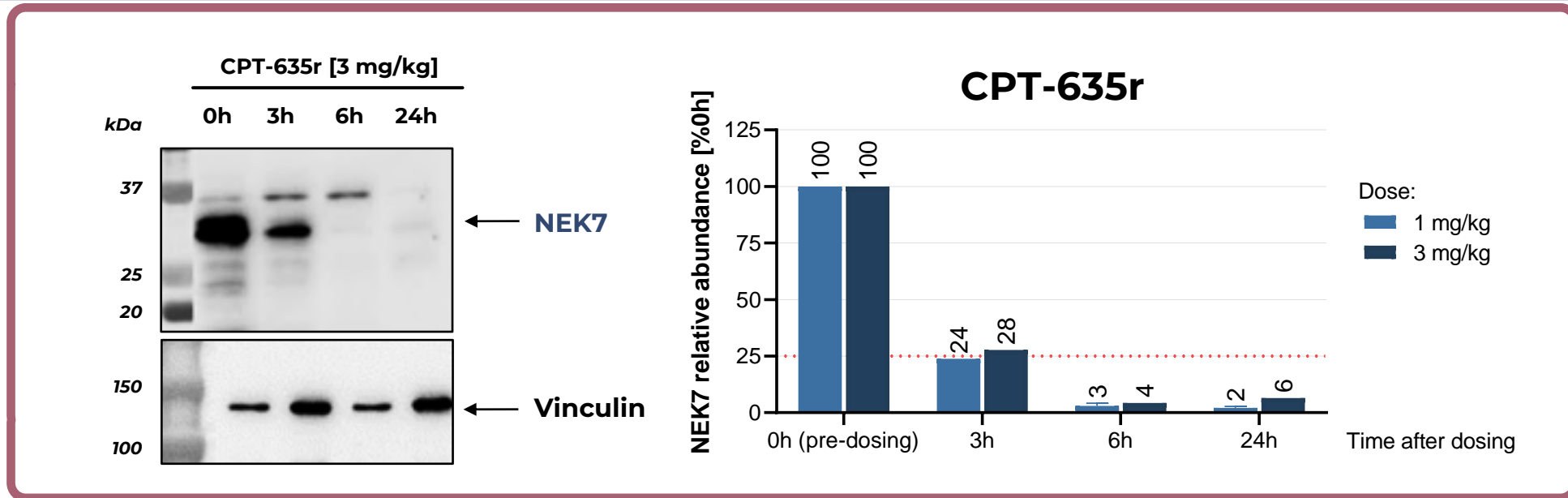

NEK7 degradation observed in monkey PBMCs isolated at 3, 6, and 24 h after PO administration of CPT-635r [1 & 3 mg/kg]

CPT-732r efficiently covers & degrades NEK7 in NHPs after a single dose

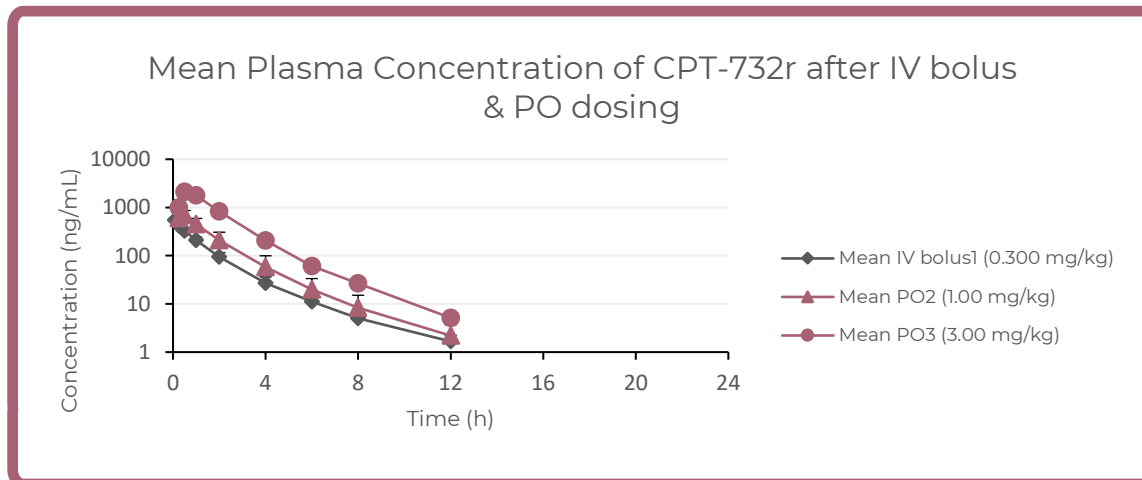
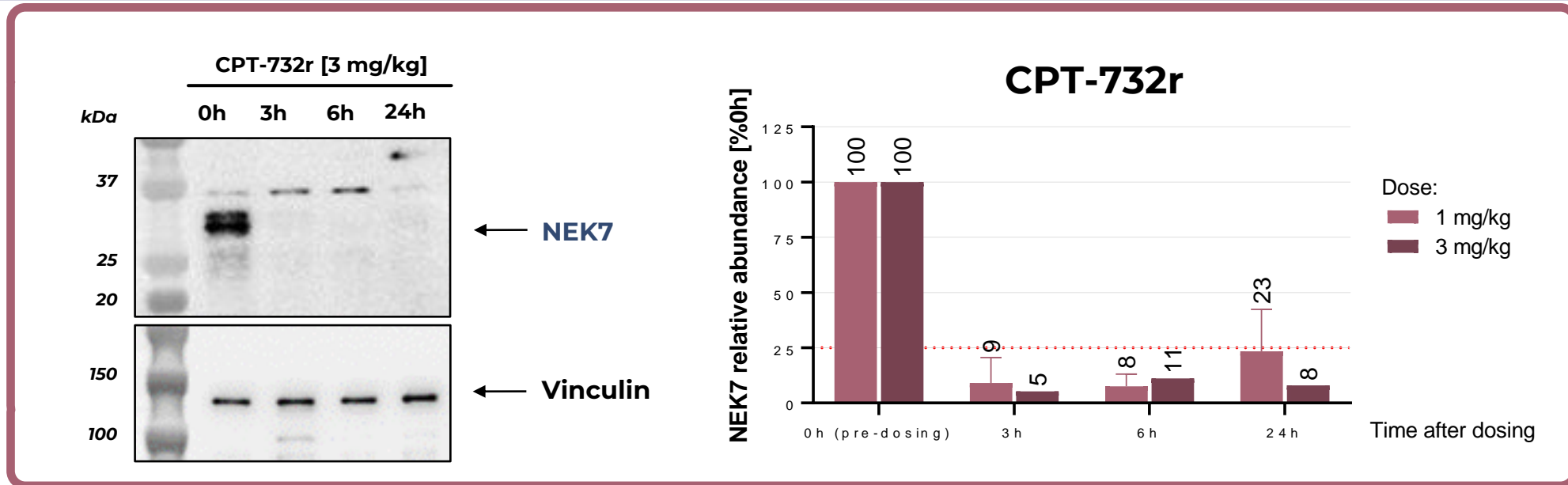

NEK7 degradation observed in monkey PBMCs isolated at 3, 6, and 24 h after PO administration of CPT-732r [1 & 3 mg/kg]

High efficacy of CPT-635r with oral dosing in EAE mouse model *in vivo*

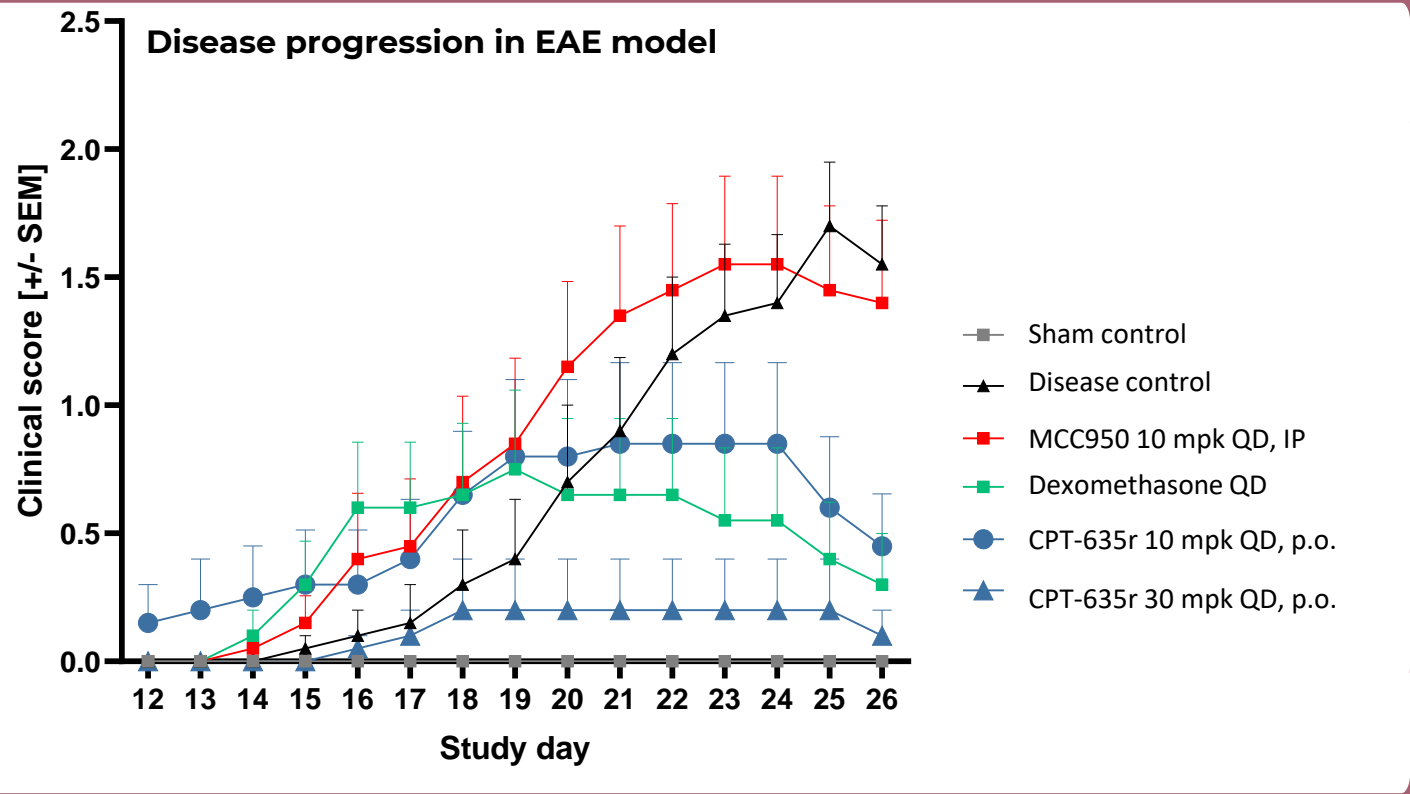

Clinical Score	Clinical Sign
0	Normal mouse; no overt signs of disease
0.5	Tail weakness/partial tail weakness (50% of length)
1	Loss of tail tonicity (complete tail paralysis)/ Limp tail
1.5	Limp tail and weakness in one hind limb
2	Partial hind limb paralysis/ Limp tail and weakness in both hind limbs
2.5	Both hind limbs have some movement, but both are dragging at the feet

Dosing: QD (once a day)
 Route of administration:
 CPT-513, dexamethasone - PO
 MCC950 - IP

C57BL/6 female mice (10 mice per group)

Clinical score/ disease index monitored based on a predefined scale including motor skills and tail / limb weakness

Treatment for 16 days did not induce any side effects

Body weight in the groups treated with NEK7 degraders was higher than in the group treated with Dexamethasone

Note: CPT-635r is approximately 40% less potent (DC50) in murine systems compared to human / primate

MOG₃₅₋₅₅ Induced Experimental Autoimmune Encephalomyelitis (EAE) In Mice

Therapeutic potential of NEK7 degraders in Collagen-Induced Arthritis model

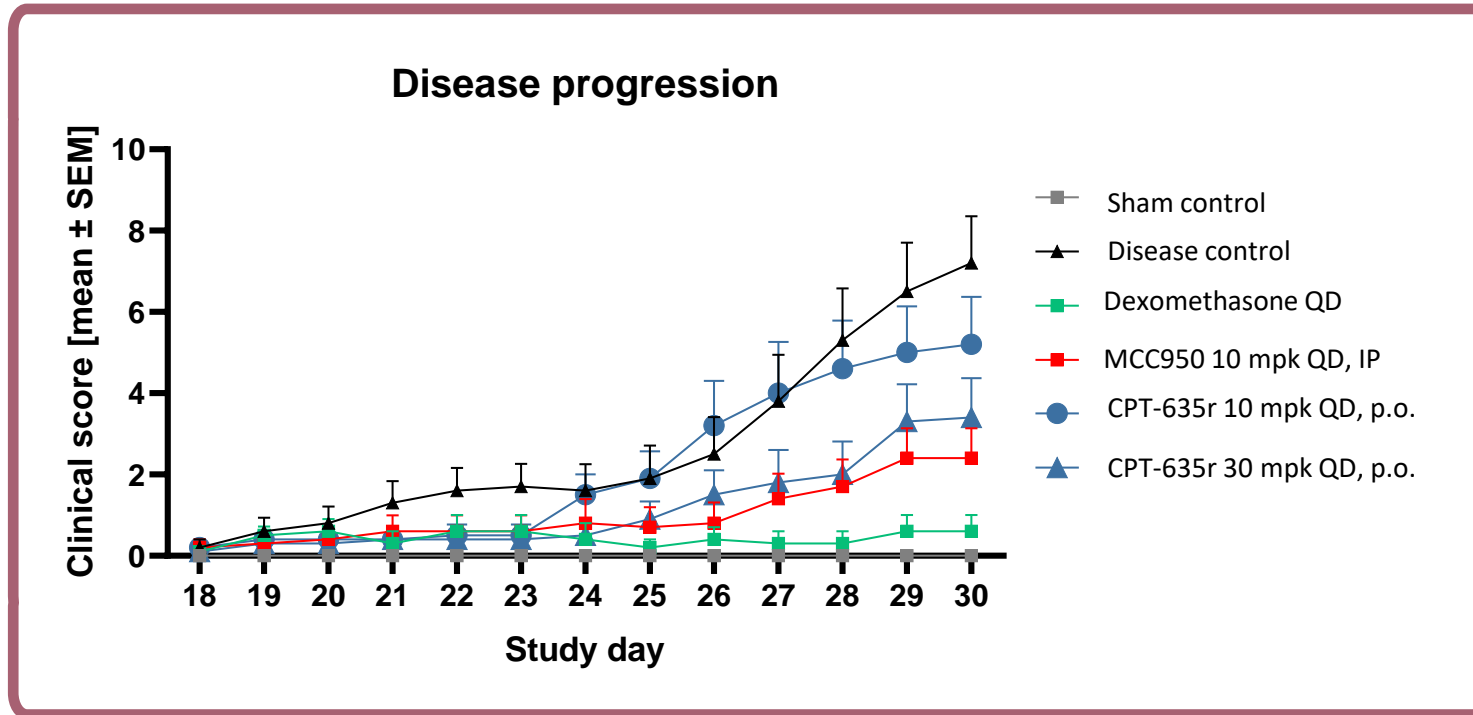

Clinical Score	Clinical Sign
0	No redness or swelling
1	Slight swelling in ankle and or redness in one toe
2	Progressive swelling from ankle to midfoot and or involvement of more than two toes
3	Swelling and inflammation in entire foot
4	Swelling and inflammation in entire foot including toes

Dosing: QD (once a day)
 Route of administration:
 CPT-513, dexamethasone - PO (oral)
 MCC950 - IP (intraperitoneally)

Male DBA1/J Mice (10 mice per group)

Clinical score/ disease index was assessed by trained, blinded personnel for swelling of digits/paws and erythema

Treatment over 32 days did not induce any side effects

Treatment with CPT-635r at a dose of 30 mg/kg reduced the clinical score by approximately 50% compared to the control group, to a degree comparable to MCC950. Dose-dependent therapeutic effect is observed (30 mpk vs.10 mpk)

T/B-cell driven; Collagen-Induced Arthritis

Differentiated safety profile of NEK7 degraders vs. NLRP3 inhibitors

	CPT-635	CPT-732	NLRP3 inhibitors
Structural features	Classical scaffold	Classical scaffold	Most inhibitors based on sulfonamides; Anhydrases as off-targets ⁵
Inhibition of IL-1β	Max. 80-90%	Max. 80-90%	100%
	NEK7	NLRP3	
Alternative functions (unrelated to inflammasome)	Suspected role in mitotic spindle formation, but not seen with CTX degraders	<ul style="list-style-type: none"> • Sterile necroinflammation, fibrosis, tissue repair¹ • Apoptosis regulation in tubular cells in kidneys (mice showed renal problems upon MCC950 administration)² • Innate immune homeostasis in the airway³ • Regulation of IL-33 production⁴ 	

1. <https://www.frontiersin.org/journals/immunology/articles/10.3389/fimmu.2023.1214289/full>
 2. <https://portlandpress.com/clinsci/article/136/2/167/230637/Adverse-renal-effects-of-NLRP3-inflammasome>
 3. [https://www.mucosalimmunology.org/article/S1933-0219\(22\)00433-0/fulltext](https://www.mucosalimmunology.org/article/S1933-0219(22)00433-0/fulltext)
 4. <https://www.nature.com/articles/s41419-021-04159-9>
 5. <https://pubs.acs.org/doi/10.1021/acscchembio.1c00218>

CT-02: Excellent degraders from two different strategies

Two series of potent NEK7 degraders:

autoimmune diseases (CPT-635) and **neurodegenerative disorders** (CPT-732, brain-penetrant)

Activity confirmed *in vitro* in mouse, monkey and human cells and *in vivo* in mice and monkeys

Specificity-driven safety demonstrated in *in vitro* analysis, *in vivo* tolerability studies and confirmed in the clean CEREP panel

PK/PD results in monkeys illustrate the attractive features of drug candidates

In vivo proof of efficacy in disease models with no signs of toxicity



CT-05: First-in-Class PKC θ Degraders for Autoimmune Disorders

PKC θ : an undrugged high value target

TCR

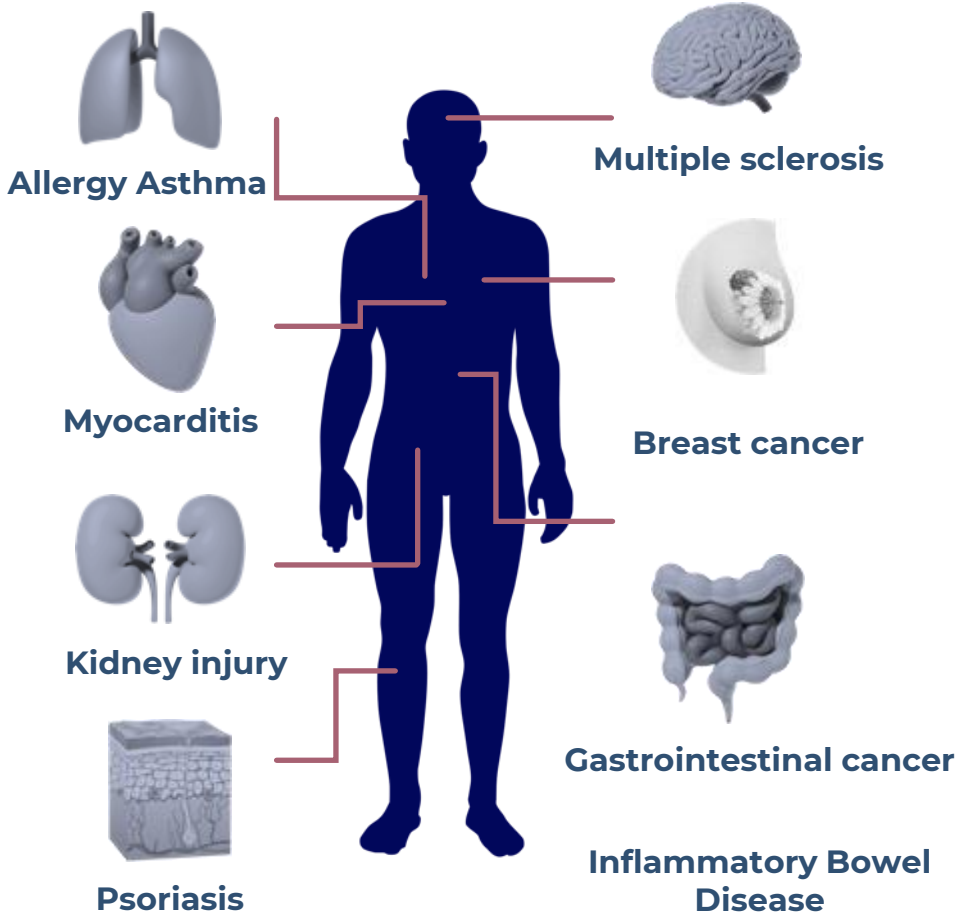
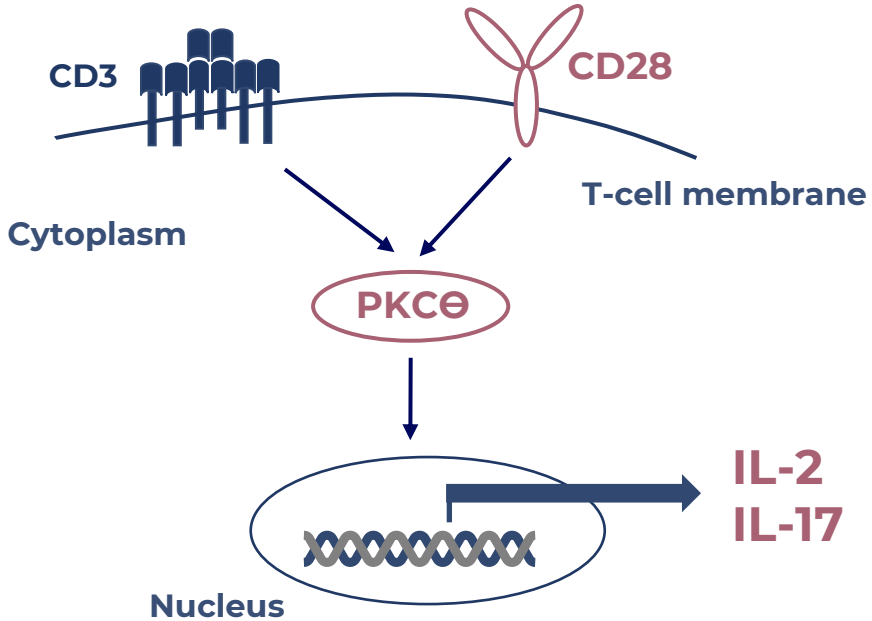

PKC θ Biology and target rationale

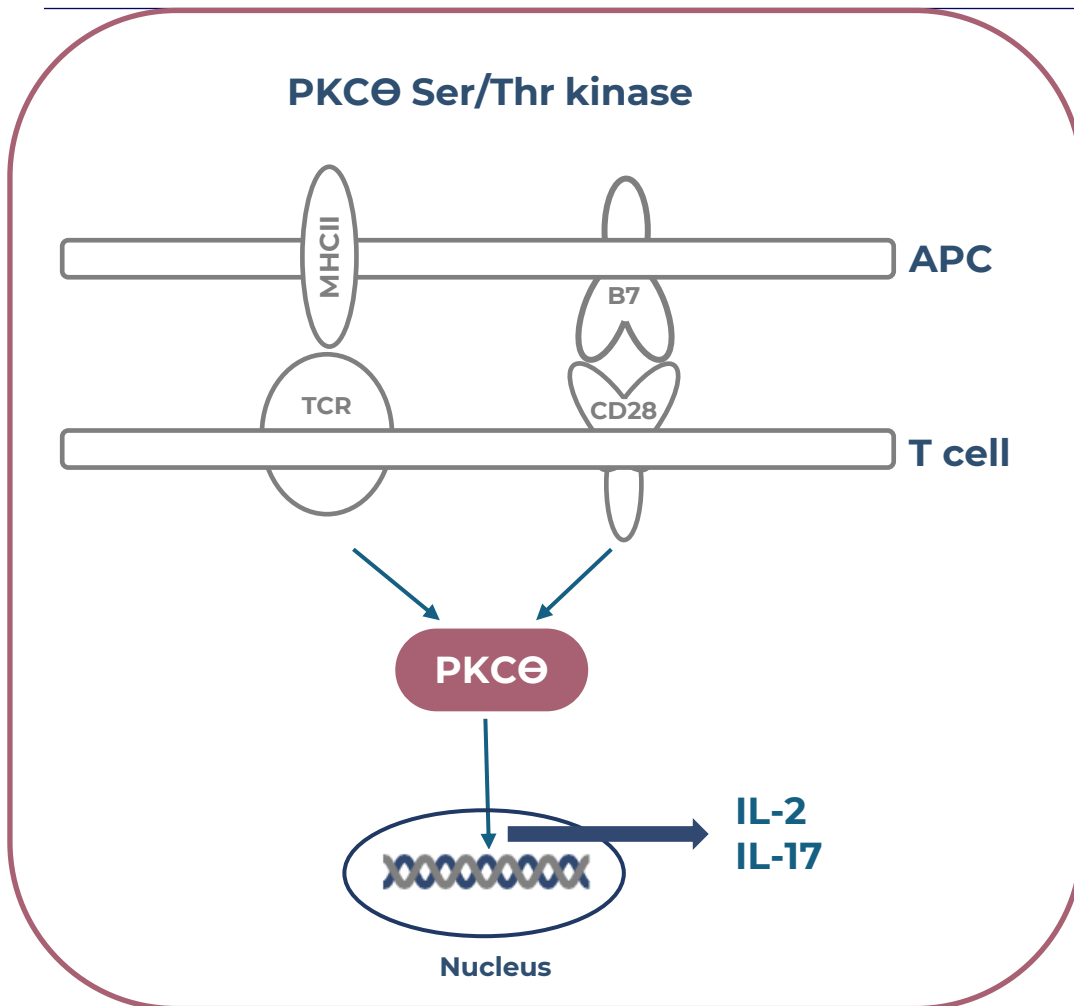

Target Biology and rationale

PKC θ has a thoroughly established role in regulatory and effector T cell functions^{1,2}

PRCKQ locus was shown associated with several immune-related diseases in multiple GWAS studies (type I diabetes, rheumatoid arthritis, celiac disease)³⁻⁶

Human and mouse genetics

PKC θ KO mice show impaired *in vivo* T cell activation, decreased IL-17 production and are protected from T cell-mediated inflammatory diseases (EAE, colitis)^{7,8}

Clinical pathway validation

PKC θ inhibitor – Sotrastaurin (AEB071) – has been shown effective in preventing IL-17 production and to have a potential for therapeutic option in psoriasis⁹⁻¹¹

Currently, undergoing clinical evaluation is a novel inhibitor from Exscientia / BMS

1. PKC-theta in regulatory and effector T cell functions, Brezar V., 2015, Front. Immunol. 6
2. Intervention of PKC- θ as an immunosuppressive regimen, Sun Z., 2012, Front Immunol. 3: 225
3. Meta-analysis of genome-wide association study data identifies additional type 1 diabetes risk loci, Cooper J.D., 2008, Nat. Genet. 40, 1399-1401
4. Common variants at CD40 and other loci confer risk of rheumatoid arthritis, Raychaudhuri S., 2008, Nat. Genet. 40, 1216-1223
5. Genome-wide association study meta-analysis identifies seven new rheumatoid arthritis risk loci, Stahl E.A., 2010, Nat. Genet. 42, 508-514
6. Meta-analysis of genome-wide association studies in celiac disease and rheumatoid arthritis identifies fourteen non-HLA shared loci, Zhernakova A., 2011, PLoS Genet. 7, e1002004

7. Mice deficient in PKC theta demonstrate impaired *in vivo* T cell activation and protection from T cell-mediated inflammatory diseases, Anderson K., 2006, Autoimmunity, 6: 469-487
8. Resistance to experimental autoimmune encephalomyelitis and impaired IL-17 production in protein kinase C θ -deficient mice, Tan S-L., 2006, J Immunol. 176(5): 2872-2879
9. The PKC inhibitor AEB071 may be a therapeutic option for psoriasis, Skvara H., 2008, J Clin Invest. 118(9): 3151-9
10. The protein kinase C inhibitor sotrastaurin allows regulatory T cell function, de Weerd A., 2013, Clin Exp. Immunol. 175(2): 296-304
11. Targeting PKC in Human T Cells Using Sotrastaurin (AEB071) Preserves Regulatory T Cells and Prevents IL-17 Production, He X., 2013, J Invest dermatol. 134(4): 975-983

Rationale for targeted degradation of PKC θ

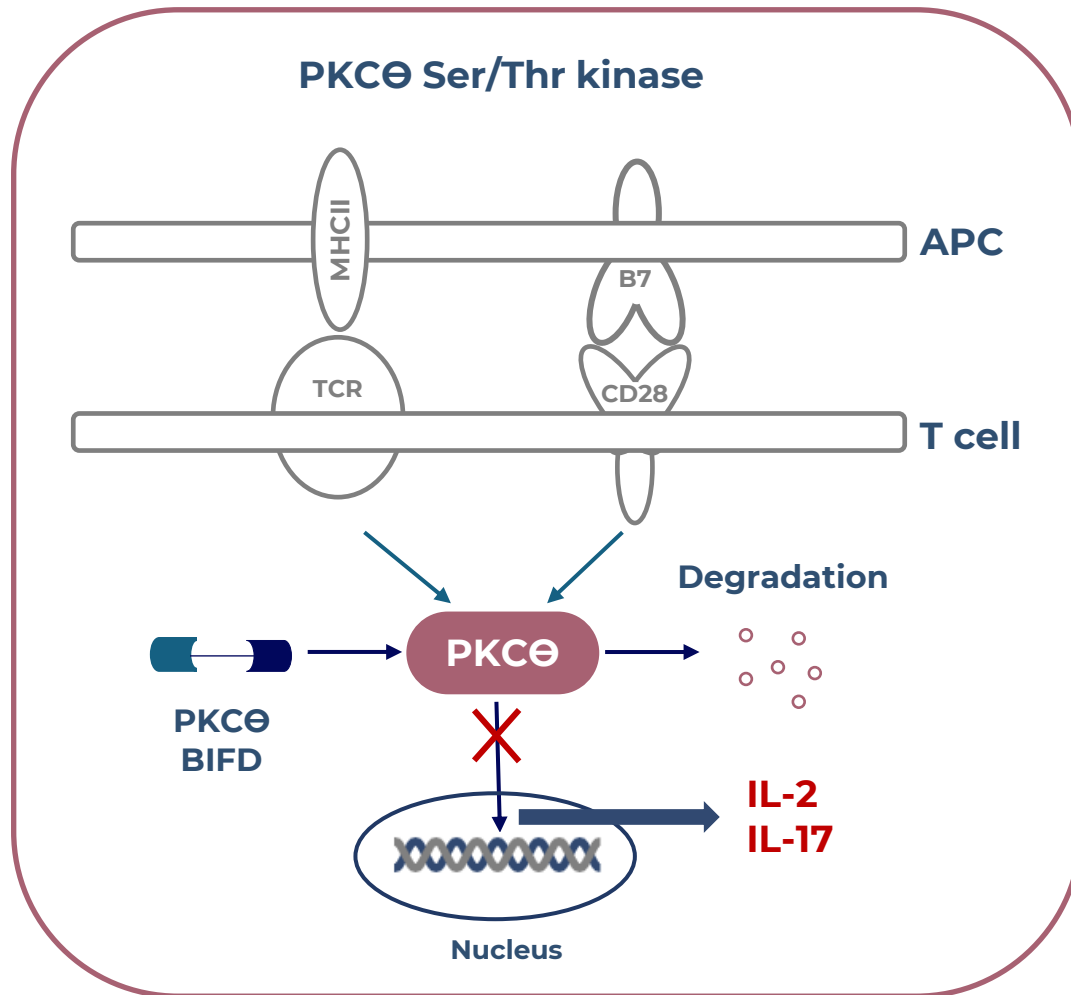

PKC θ is a master regulator of T cell differentiation, proliferation and functions.

Drawbacks of the 1st and 2nd generation PKC θ inhibitors were related to multiple side effects due to unspecificity and insufficient target coverage.

The degrader offers disabling not only kinase but also scaffolding functions of the protein.

PKC θ degradation has the potential to abolish T cell survival signal and promote the apoptosis of activated, self-reactive T cells in autoimmune diseases.

CPT-763 is highly selective in a panel of assays

Inhibitor shows significant effects on GIST-T1 non-immune cells
 Degradar has no effect in same system

**Big Pharma compound
 CPT-191**
Inadequate Selectivity

CPT-763
High Selectivity

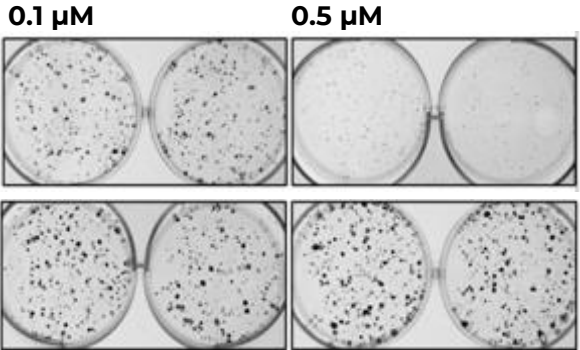

Compound	IC ₅₀	I _{max}	DC ₅₀
CPT-763	55 nM	82 %	29 nM
CPT-191	98 nM	99 %	N/A

IC₅₀ and I_{max} values obtained in ELISA analysis

Excellent selectivity against a large number
 of kinases

KinomeScan results TREEspot™ Interaction Map panel of ca. 450 kinases

CPT-763 @ 10000nM

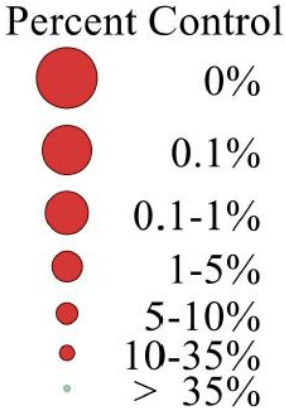
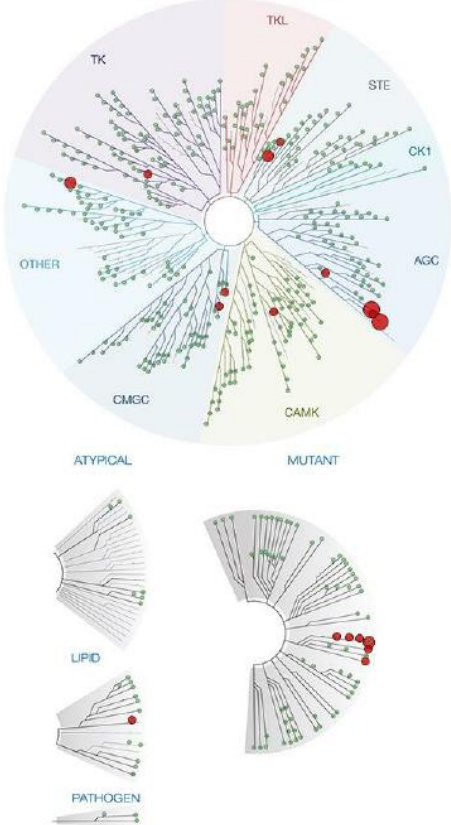

Summary

- Established a screening workflow that allows for discovery of PKC θ degraders superior to existing inhibitors
 - Highly selective for PKC θ with no off-target toxicity
- Early stage of lead optimisation with 2 compounds has demonstrated:
 - *In vitro*: degradation of PKC θ in mouse & human T-cells & inhibition of IL-2 in human T-cells
 - *In vivo*: degradation of PKC θ in mouse splenocytes
- Next steps:
 - Partnering discussions

Optigrade™ Targeted Protein Degradation Platform

Molecular glues

Bifunctional Degraders

Novel E3 ligases

LiLis™ program: developing novel E3 ligases beyond CRBN

- Expanding the range of targets for effective degradation
- CRBN down regulation-driven resistance mechanisms in cancer
- Crowded IP space for CRBN binders
- Opportunity for cell type or cell compartment specificity

In-house developed E3 ligase production platform and is generating leads for novel E3s

Finance Highlights

Balance sheet and cash position

Consolidated statement of financial position (US\$, M)

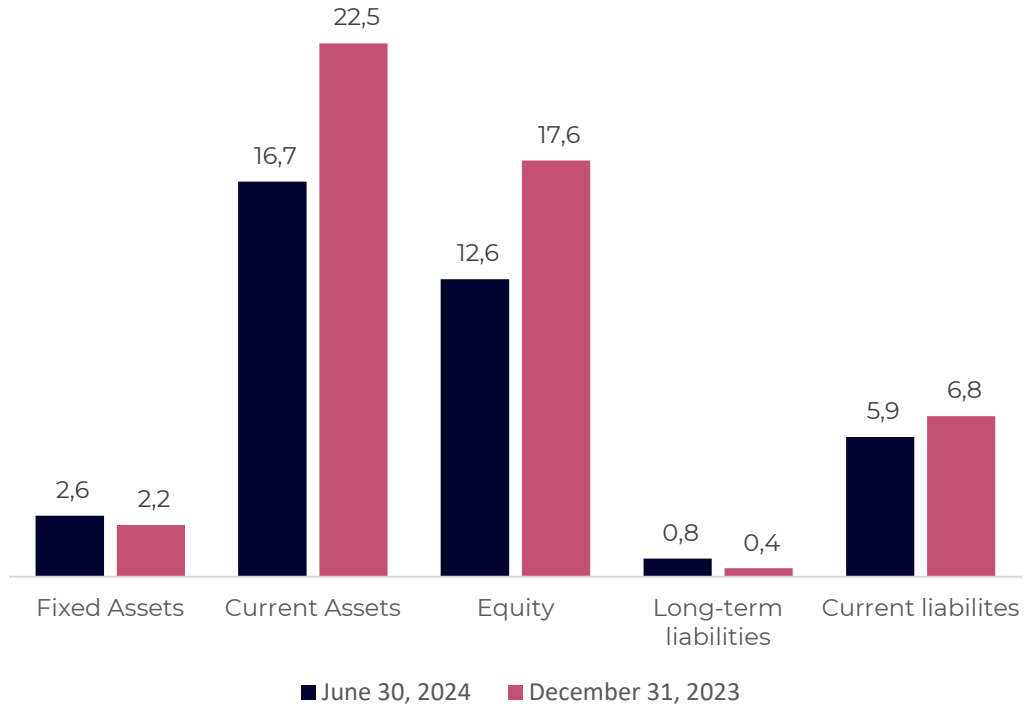

Exchange rate USD/PLN as of June 28, 2024 – 4,0320

Finance

Cash position

Available funding secured (US\$ M; as of June 30, 2024):

Total : US\$ M 27,9*

■ US\$ M 14,0 cash

■ US\$ M 13,9 available grants (NCBR; ABM)

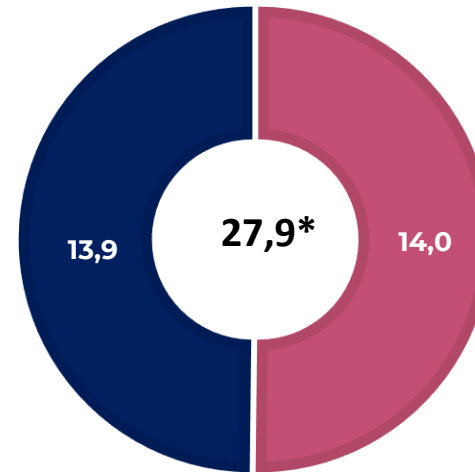

* Amount includes grant awarded for phasing in CT-03 and CT-01 project.

R&D costs in H1 2024:

Total : US\$ M 6,2

Cash outflow in H1 2024:

Total : US\$ 4,3 M

Balance sheet and cash position

Consolidated statement of financial position (EUR, M)

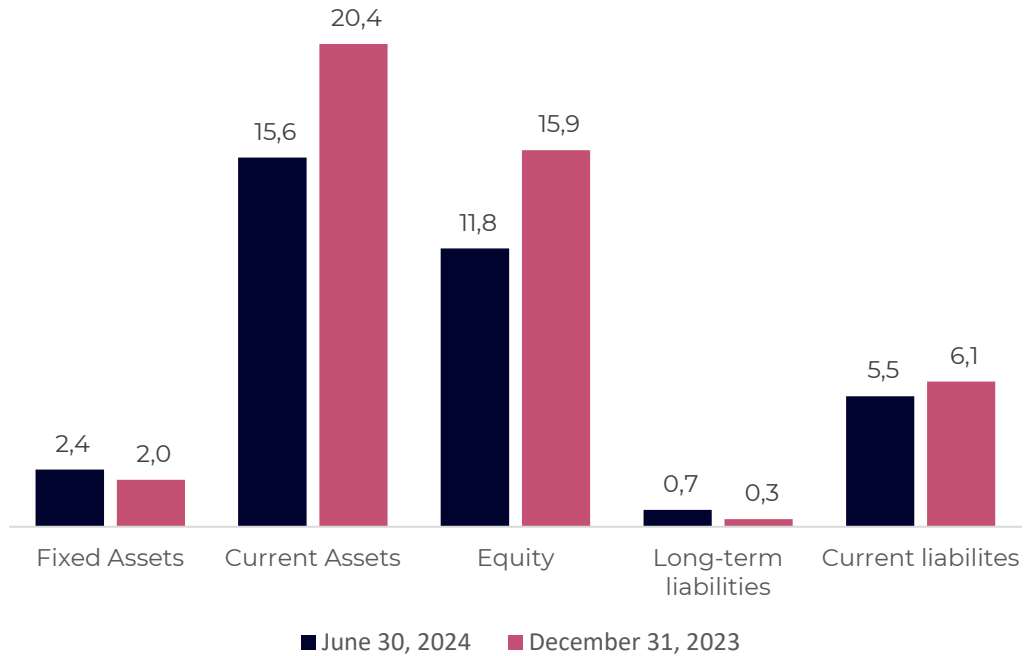

Exchange rate USD/PLN as of June 28, 2024 – 4,3130

Finance

Cash position

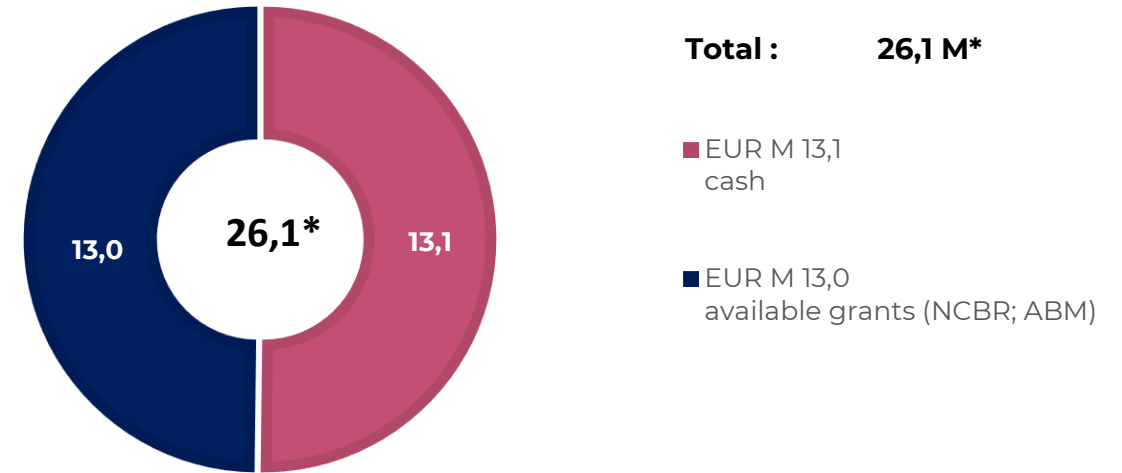

* Amount includes grant awarded for phasing in CT-03 and CT-01 project.

R&D costs in H1 2024:

Total: EUR 5,8 M

Net Operational Cash Outflow in H1 2024

Total: EUR 4,1 M

Current (September 2024) guidance indicates cash runway until Q3 2025

Balance sheet and cash position

Consolidated statement of financial position (PLN, M)

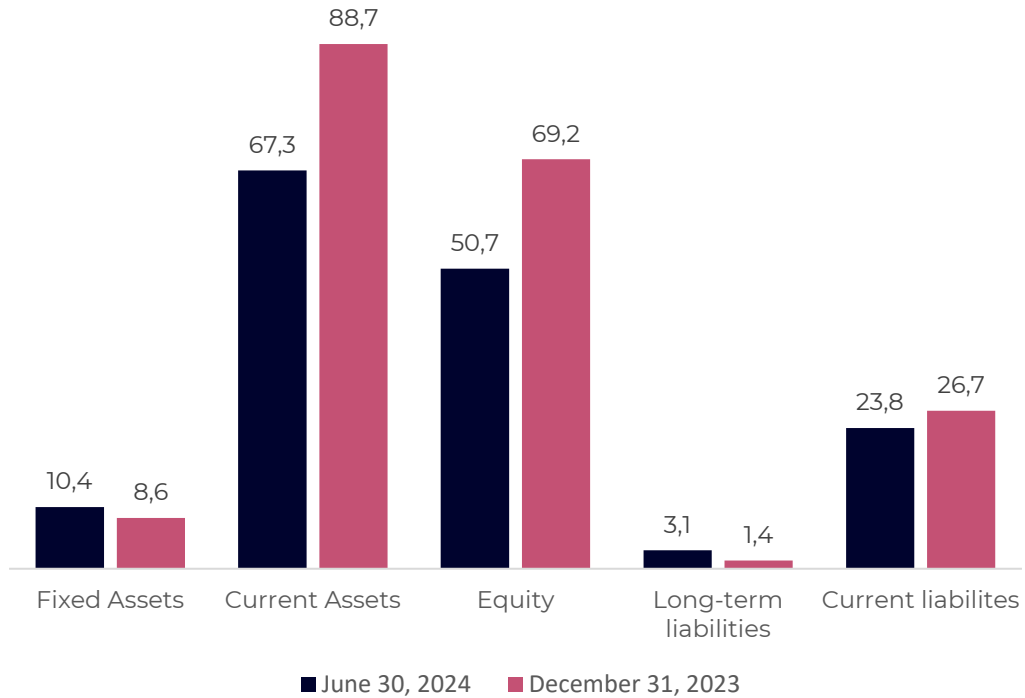

Cash position

Available funding secured (PLN M; as of June 30, 2024):

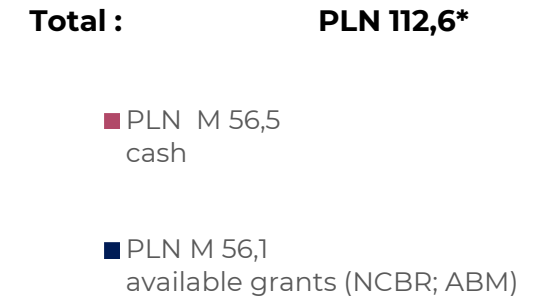

* Amount includes grant awarded for phasing in CT-03 and CT-01 project.

R&D costs in H1 2024:

Total: PLN 25,2 M

Net Operational Cash Outflow in H1 2024:

Total: PLN 17,5 M
(H1 2023 - PLN 31,5 M)

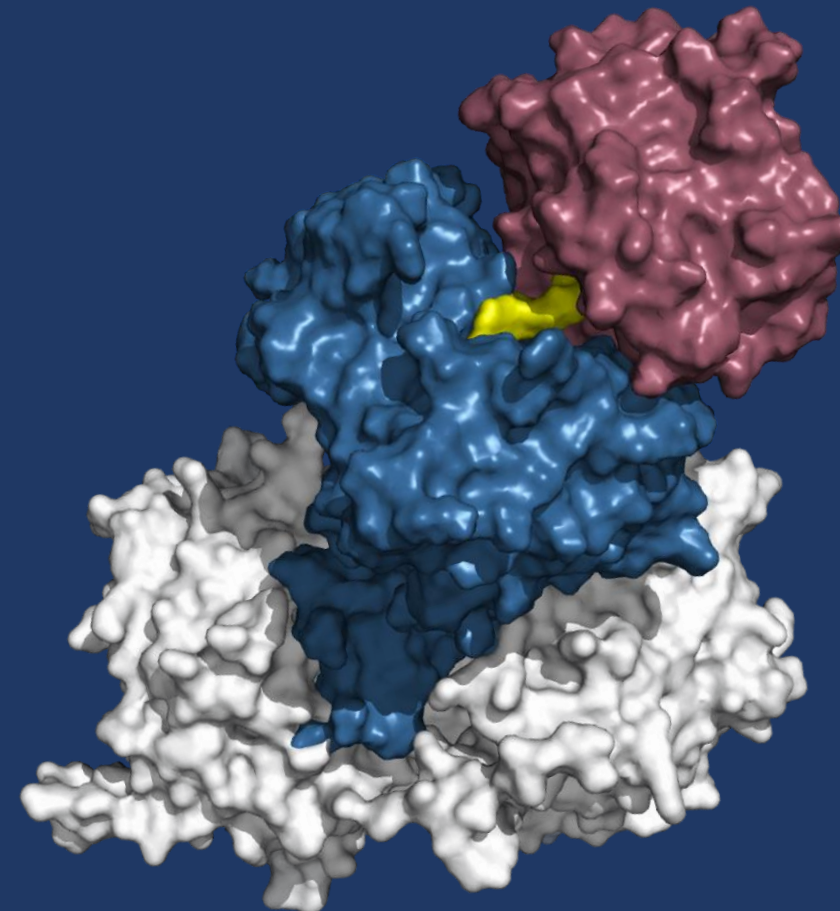

Captor Therapeutics S.A.



ul. Duńska 11
54-427 Wrocław, Poland



Captor Therapeutics GmbH

Hegenheimermattweg 167A
4123 Allschwil, Switzerland

Contact: investor.relations@captortherapeutics.com

Projects co-financed by the European Regional Development Fund:

Discovery and development of a new clinical drug candidate for the eradication of cancer stem cell in the treatment of hepatocellular carcinoma, through degradation of oncofetal transcription factor” (FENG.01.01.01-00-0740/19-00)

Discovery and development of a new clinical drug candidate for the eradication of cancer stem cell in the treatment of hepatocellular carcinoma, through degradation of oncofetal transcription factor - Stage II
(POIR.01.01.IP.01-1001/23)

Inducing apoptosis with small molecules as therapeutic intervention in multiple severe malignancies (POIR.01.01.01-00-0956/17-01)

Inducing apoptosis with small molecules as therapeutic intervention in multiple severe malignancies – Stage II (FENG.01.01-IP.01-1002/23)

Application of targeted protein degradation technology in the treatment of psoriasis and rheumatoid arthritis (POIR.01.02.00-00-0079/18-00)

Development of an integrated technology platform in the field of targeted protein degradation and its implementation to the pharmaceutical market (POIR.01.01.01-00-0931/19-00)

Discovery and development of non-toxic ligase ligands and their application in the treatment of autoimmune diseases
(POIR.01.01.01-00-0741/19-00)

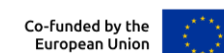

Project co-financed by the state budget from the Medical Research Agency:

Design and clinical development of a first-in-class small-molecule drug candidate for the treatment of colorectal cancer based on the stimulation of immune cells to increase anti-cancer activity through induced protein degradation (2022/ABM/06/00001 - 00)

